

Industrial HVLS Fan User's Manual

READ AND SAVE THESE INSTRUCTIONS



This manual applies to fans manufactured beginning February 2026 with serial numbers F61852534 and higher.



E506041

▲ WARNING

Do not install, operate, or service this product unless you have read and understand the Safety Practices, Warnings, and Installation and Operating Instructions contained in this manual. Failure to do so could result in death or serious injury.

**User's Manual
Installation, Operations
Maintenance and Parts**

Part No. 6024430E

A part of ASSA ABLOY
© ASSA ABLOY 2026

LIMITED PRODUCT WARRANTY

Warranty information for the Industrial HVLS Fan can be found by scanning the QR codes or clicking the links below.



Click [here](#) to view the 4Front U.S. and Canada Warranty.

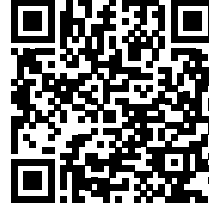

Click [here](#) to view the International Warranty.

TABLE OF CONTENTS

LIMITED PRODUCT WARRANTY	3
INTRODUCTION	7
HOW TO USE THIS MANUAL	7
SAFETY SIGNAL WORDS.....	7
SAFETY PRACTICES	8
OWNER'S RESPONSIBILITIES	11
NATIONAL FIRE PROTECTION ASSOCIATION STANDARD	11
HARDWARE	12
FAN KIT.....	13
PACKING KIT (STANDARD)	13
REQUIRED TOOLS	13
PRIOR TO FAN INSTALLATION.....	14
FOR OPTIONAL NETWORK (IFAN OR MULTI-FAN) FANS ONLY	14
INSTALLATION CONSIDERATIONS	15
ROOF ANGLES.....	16
CLEARANCE FROM HVAC EQUIPMENT	17
CLEARANCE FROM SOLID CONSIDERATIONS.....	18
BUILDING STRUCTURE	19
PLACEMENT AND SPACING.....	19
INSTALLATION	21
FAN MOUNT ASSEMBLY	21
INSTALL FAN MOUNT	22
INSTALL THE POWER HEAD (MOTOR/GEARBOX ASSY)	25
INSTALL THE GUY WIRES	26
INSTALL THE VFD BOX	27
INSTALL THE MOTOR COVER (5-BLADE MODELS ONLY)	28
INSTALL THE BLADES	29

VERIFY CLEARANCE AND CABLE TENSION.....	30
INSTALL REMOTE CONTROL.....	30
ELECTRICAL SCHEMATICS.....	32
1PH WIRING DETAILS.....	32
3PH WIRING DETAILS.....	34
VARIABLE FREQUENCY DRIVE.....	36
MULTI FAN WIRING DETAILS — OPTIONAL.....	37
IFAN WIRING DETAILS	38
TEMP/HUMIDITY CONTROL WIRING DETAILS — OPTIONAL	39
FIRE CONTROL SYSTEM FAN SHUTDOWN — OPTIONAL	40
FIRE CONTROL SYSTEM FAN SHUTDOWN PANEL — STANDARD INSTALLATION (6015291).....	41
FIRE CONTROL SYSTEM FAN SHUTDOWN PANEL — NETWORK INSTALLATION (6020547).....	42
550-600V SUPPLY WIRING DETAILS — OPTIONAL	43
HMI SETUP	44
DEFINE THE NUMBER OF FANS.....	44
SET THE DIAMETER OF THE FANS	44
ENABLE THE TEMPERATURE CONTROL OPTION (OPTIONAL)	45
SET THE TEMPERATURE SETTINGS.....	45
ENABLE THE WIND CONTROL OPTION.....	46
SET THE UNIT OF WIND SPEED	46
CORRECT ERRORS DURING HMI CONFIGURATION.....	46
POST CONFIGURATION TASKS	47
TEMPERATURE CONTROL INSTALLATION — OPTIONAL	47
WIND CONTROL INSTALLATION — OPTIONAL.....	47
OPERATING INSTRUCTIONS.....	48
FAN CONTROL SCREEN	48
VERIFY PRIOR TO OPERATION	49
LOGIN SCREEN	49

NORMAL FAN OPERATION	49
CHANGE THE FAN ROTATION DIRECTION	50
DIAGNOSTIC SCREEN	50
PASSCODE PROTECTION	52
MULTI-FAN CONTROL — OPTIONAL	52
TEMPERATURE CONTROL — OPTIONAL	53
PLANNED MAINTENANCE	54
TROUBLESHOOTING GUIDE	56
VARIABLE FREQUENCY DRIVE (VFD) FAULT CODES	58
COMPONENTS AND SPECIFICATIONS	59
VFD BOX	59
MOTOR	59
GEARBOX	59
PARTS LIST — FAN	61
PARTS LIST — VFD BOX	65
3-BLADE	66
5-BLADE	67
PARTS LIST — REMOTE CONTROL PANEL	70
PARTS LIST — TEMP CONTROL (OPTIONAL) - 6022769	71

INTRODUCTION

Welcome and thank you for choosing this industrial fan from 4FRONT Engineered Solutions, Inc.

This User's Manual contains information you need to safely install, operate, and maintain the fan. It also contains a complete parts list and information about ordering replacement parts. Please keep and read this User's Manual before using your new fan.

For more information, please visit our website at www.epicfan.com.

HOW TO USE THIS MANUAL

This section explains the visual clues and conventions that will help you quickly locate the information you need.

BASIC ELEMENTS

- Names of menus, buttons, icons, and fields are highlighted in bold text
- Text highlighted in blue indicates a link you can click to navigate to another topic.

SAFETY SIGNAL WORDS

You may find safety signal words such as DANGER, WARNING, CAUTION, or NOTICE in the User's Manual. The use of Safety Signal Words is explained below.

▲ DANGER

Indicates an imminently hazardous situation which, if not avoided, will result in death or serious injury.

▲ WARNING

Indicates a potentially hazardous situation which, if not avoided, could result in death or serious injury.

▲ CAUTION

Indicates a potentially hazardous situation which, if not avoided, may result in minor or moderate injury.

NOTICE

Notice is used to address practices not related to personal injury.

SAFETY PRACTICES

▲ WARNING

READ THESE SAFETY PRACTICES BEFORE INSTALLING, OPERATING, OR SERVICING THE FAN,

READ AND FOLLOW THE OPERATING INSTRUCTIONS IN THIS MANUAL BEFORE OPERATING THE FAN. If you do not understand the instructions, ask your supervisor for instruction.

To reduce the risk of personal injury, do not bend the blade brackets when installing the brackets or cleaning the fan. Do not insert foreign objects in between rotating fan blades.

▲ DANGER

To reduce the risk of fire, HVLS fan motor assemblies must be installed with the blade assemblies that are marked on their cartons to indicate the suitability with this model, Other blade assemblies cannot be substituted.

Be certain to follow the instructions in this manual.

▲ WARNING

Installation of the equipment must comply with local and national electrical codes and must be in accordance with ANSI/NFPA 7-1999.

Do not use this industrial fan until you have received proper training. Improper use could result in property damage, bodily damage, bodily injury, and/or death. Read and follow the complete [Operating Instructions on page 48](#) before use. If you do not understand the instructions, ask your supervisor to explain them to you or call your local distributor.

DO NOT USE THE FAN IF IT APPEARS DAMAGED OR DOES NOT OPERATE PROPERLY. Inform your supervisor immediately.

Do not operate the fan until all personnel, building structure, and equipment are clear of all moving parts and exclusion zones. Install guards as required.

To reduce the risk of electrical shock, do not expose to water or rain.

Support directly from the building structure. Do not install the fan unit onto a structure of insufficient strength. Consult a professional engineer or registered architect. Improper installation of the fan could result in death or serious injury.

▲ WARNING

Before service, inspection, or cleaning, make certain the power is disconnected and properly locked out.

If the fan does not operate properly using the procedures in this manual, BE CERTAIN TO REMOVE POWER FROM THE UNIT AND LOCK-OUT THE DISCONNECTED ON THE POWER CIRCUIT. Call your local distributor for service,

Keep your body clear of moving parts at all times.

All electrical troubleshooting and repair must be done by a qualified technician and meet all applicable codes.

If it is necessary to make troubleshooting checks inside the VFD box with the power on, USE EXTREME CAUTION. Do not place fingers or un-insulated tools inside the enclosure. Touching wires or other parts inside the enclosure could result in death or serious injury.

▲ WARNING

Variable Frequency Drive (VFD) fan controllers contain high voltage capacitors. Before working on the fan controller, ensure isolation of the main voltage supply and verify voltage has bled off prior to beginning Work. Failure to do so may result in death or serious injury.

If you have problems or questions, contact your local distributor for assistance.

▲ WARNING

To reduce the risk of injury to persons, install the fan so that the blades are at least 3.05m (10') above the floor.

▲ WARNING

If unusual oscillating movement is observed, immediately stop using the ceiling fan and contact the manufacturer, its service agent, or suitably qualified persons.

▲ CAUTION

Installation work and electrical wiring must be done by qualified person(s) in accordance with all applicable codes and standards.

▲ CAUTION

When cutting or drilling into wall or ceiling, do not damage electrical wiring and other hidden utilities.

▲ CAUTION

Exercise caution and common sense when powering the fan. Do not connect the fan to a damaged or hazardous power source. Do not attempt to resolve electrical malfunctions or failures on your own.

▲ CAUTION

When service or replacement of a component in the fan requires the removal or disconnection of a safety device, the safety device is to be reinstalled or remounted as previously installed.

▲ WARNING

There is a risk of fire, electric shock, or injury to persons during cleaning and user-maintenance. Disconnect the fan from the power supply before servicing.

▲ WARNING

Stay alert. Watch what you are doing. Use common sense when installing fans. Do not install fans when tired, or under the influence of drugs, alcohol, or medications. A moment of inattention while installing fans may result in serious personal injury.

▲ CAUTION

The installation of this fan requires the use of some power tools. Follow the safety procedures found in the owner's manual for each of these tools and do not use them for purposes other than intended by the manufacturer.

NOTICE

This appliance is not intended for use by person (including children) with reduced physical, sensory, or mental capabilities, or lack of experience and knowledge, unless they have been given supervision or instruction concerning the use of the appliance by a person responsible for their safety. Children should be supervised to ensure they do not play with the appliance.

OWNER'S RESPONSIBILITIES

The owner's responsibilities include the following:

The owner should recognize the inherent danger of the interface between the industrial fan and shop worker. The owner should, therefore, train and instruct operators in the safe use of the industrial fan.

Nameplates, cautions, instructions, and posted warnings shall not be obscured from the view of operating or maintenance personnel for whom such warnings are intended. Warnings which are worn or non-legible should be replaced.

Manufacturer's recommended periodic maintenance and inspection procedures in effect at the date of shipment shall be followed and written records of the performance of these procedures should be kept.

Industrial fans that are structurally damaged or have experienced impacts from external sources shall be removed from service, inspected by the manufacturer's authorized representative and repaired as needed before being placed back into service.

The owner shall see that all nameplates and maintenance manuals are provided to users.

Modifications or alterations of industrial fans shall be made only with written permission of the original manufacturer.

NATIONAL FIRE PROTECTION ASSOCIATION STANDARD

In accordance with NFPA 13 Standard from the National Fire Prevention Association as referenced in sections 12.1.4 and 11.1.7: High Volume Low Speed (HVLS) Fans: The installation of HVLS fans in buildings equipped with sprinklers, including ESFR sprinklers, shall comply with the following:

- The maximum fan diameter shall be 24 feet (7.3m).
- The fan shall be approximately centered between four adjacent sprinklers.
- The vertical clearance from the fan to the sprinkler deflector shall be a minimum of 3 feet (0.9m).
- All fans shall be interlocked to shut down immediately upon receiving a water flow signal from the alarm system in accordance with the requirements of *NFPA 72-National Fire Alarm and Signaling Code*.

HARDWARE

Mount — Building

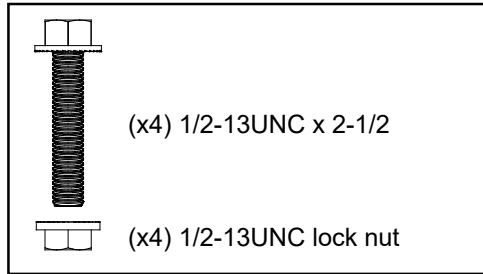

Mount — Assembly

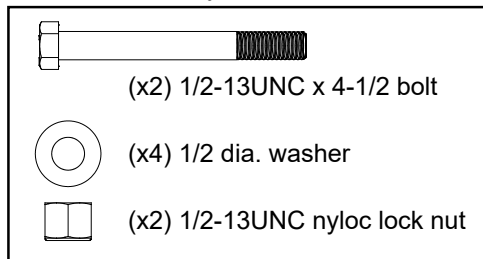

Mount — Motor frame

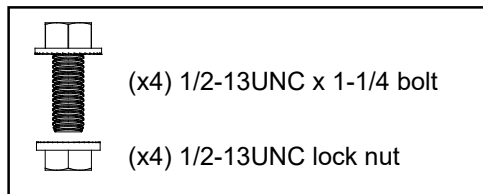

Mount — Blade

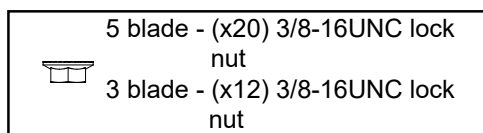

Mount — Fan cover - 5 blade only

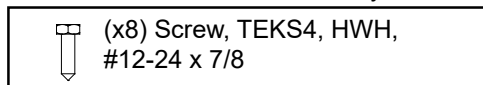

Fastener torque requirements

Description	Torque	Wrench size
1/2 dia mount hardware	44-48 ft-lbs.	3/4 hex
3/8 dia blade mount hardware	24-28 ft-lbs.	9/16 hex
Cable clamp, guy wire	Secure tight	5/16 nut driver
Cable clamp, safety cable	Secure tight	1/2 nut driver
Motor cover fastener	Secure tight	5/16 nut driver

Guy wire assembly

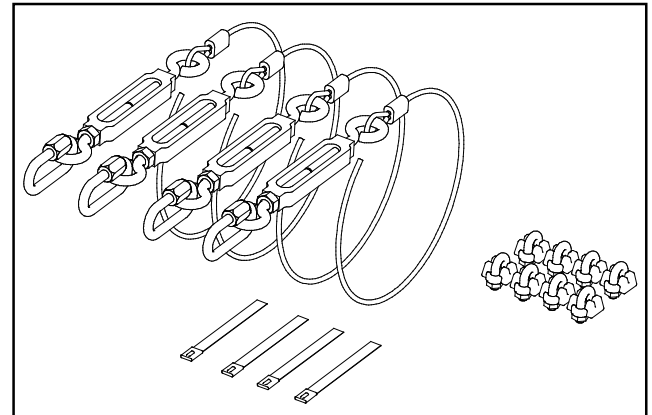

Safety cable

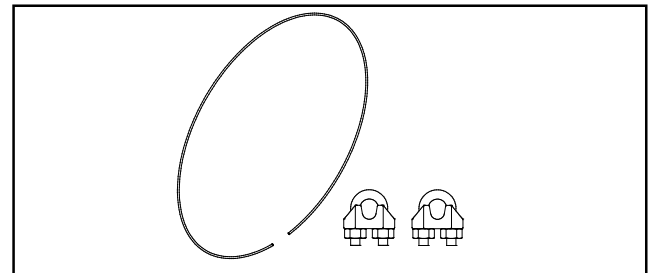

Identification labels

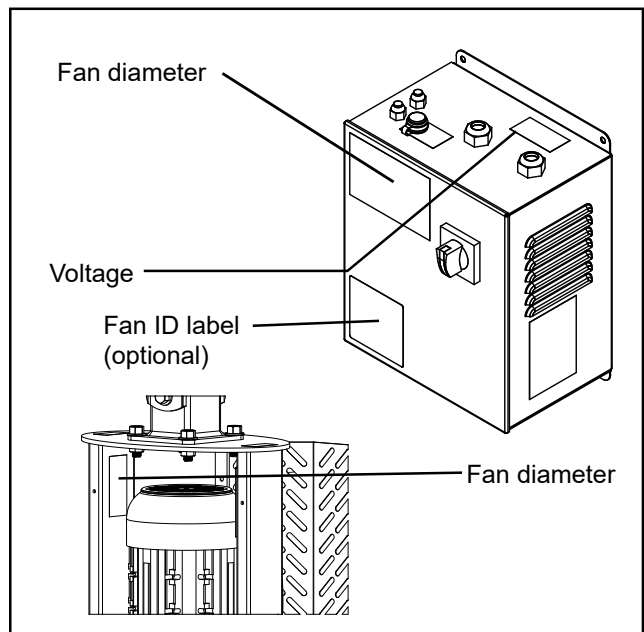

NOTE:

Additional spare hardware is provided as a courtesy.

FAN KIT

PACKING KIT (STANDARD)

1. Blade Box - 3 or 5 blades depending on model
2. Fan Motor Box
 - a. Motor/gearbox assembly
 - b. Motor covers (5-blade models only)
 - c. Remote control panel with junction box. (Option)
 - d. Category 5e cable — 100 ft. (blue) (Option)
 - e. Mounting hardware. See [Hardware on page 12](#).
 - f. Variable Frequency Drive (VFD) box.

REQUIRED TOOLS

- Wrenches: 7/16, 9/16, 3/4 (x2), 1/2
- Sockets: 7/16, 1/2, 9/16, 3/4
- Nut drivers: 1/4, 5/16
- Torque wrench: 15-60 lb-ft (for use with sockets)
- Wire strippers
- 1/4" cable cutter
- Tape measure
- Spirit level, short
- Gloves
- For laminated wood beam installations, a drill and 1/2" diameter drill bit are required.

PRIOR TO FAN INSTALLATION

1. Ensure the supplied voltage matches the fan voltage. A label containing voltage information specific to the individual fan is located on top of the VFD box.
2. Ensure the blade length matches the fan model size by consulting the fan model designation located on the side of the fan powerhead frame. See **Figure 1**.
3. Ensure all mounting hardware shown in [Hardware on page 12](#) is present.



Unpacking the Fan
Click [here](#) to view the video

FOR OPTIONAL NETWORK (IFAN OR MULTI-FAN) FANS ONLY

Ensure the Fan Network Address number matches the network layout drawing where applicable. Consult the square Network Address label on the front of the VFD enclosure.

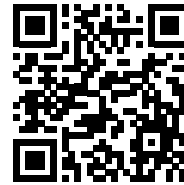

Handling the Components
Click [here](#) to view the video.

INSTALLATION CONSIDERATIONS

ROOF SLOPE

NOTICE

The chart below does not account for any possible obstructions below the mounting positions. All fans must still maintain 3' between blades and typical obstructions.

Figure 1

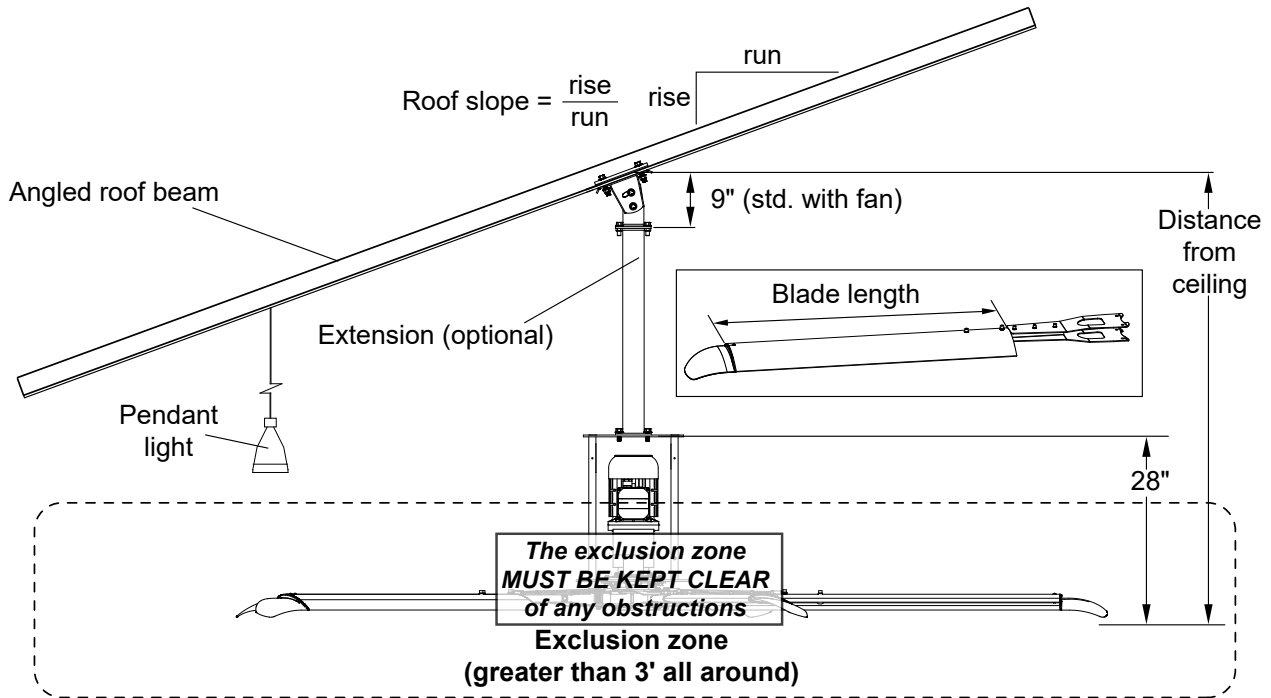

INDUSTRIAL FAN								
Roof Slope*	0	2/12	3/12	4/12	Hanging Weight (LB/KG)		Maximum Torque (lb-ft.)	Blade Length (in)
Roof Angle*	0	9.5°	14.0°	18.4°	3 Blade	5 Blade		
Fan Diameter	Extension requirement from mounting point (FT)							
8	0	1	1	2	155/70	174	300	21.16
10	0	1	2	2	160/73	182	300	33.16
12	0	1	2	2	165/75	190	300	45.16
14	0	2	2	3	170/77	198	300	57.16
16	0	2	2	3	175/79	206	300	69.16
18	0	2	3	3	180/82	214	300	81.16
20	0	2	3	4	185/84	222	300	93.16
24	0	2	3	4	195/88	245	300	117.16

* Non-standard obstructions may require additional length to the extensions. Please consult the factory for additional

clarification on non-standard obstructions and assistance with fan placement and extension selection.

⚠ WARNING

Failure to maintain exclusion zones outlined in this section could result in fan failures, including blade separation, which could result in death or serious injury. DO NOT operate fans when physical obstructions or HVAC air flows extend into exclusion zones. Regularly inspect fans to ensure exclusion zones remain clear of interference before operating the fan.

All fan blade parts must be greater than 3' from all obstructions including lights, cables, sprinklers, and other building components and greater than one (1/2) fan diameter from any wall to the end of the blade.

ROOF ANGLES

For roof angles in excess of 20°, consult the factory. The extension lengths shown are minimum recommendations only, based solely off roof pitch and fan diameter. Other considerations, such as placement of lights, sprinkler systems, HVAC systems, etc., must be evaluated when determining extension requirements. The fan blades must be at minimum 10' above the floor.

CLEARANCE FROM HVAC EQUIPMENT

For applications near HVAC equipment, such as diffusers, radiant heaters, exhaust fans, louvers, etc., the HVLS fan must be installed at minimum distances. Refer to the figures below.

- Fans located above HVAC equipment must have a minimum clearance of greater than or equal to 1 fan diameter. See **Figure 2**.

Figure 2

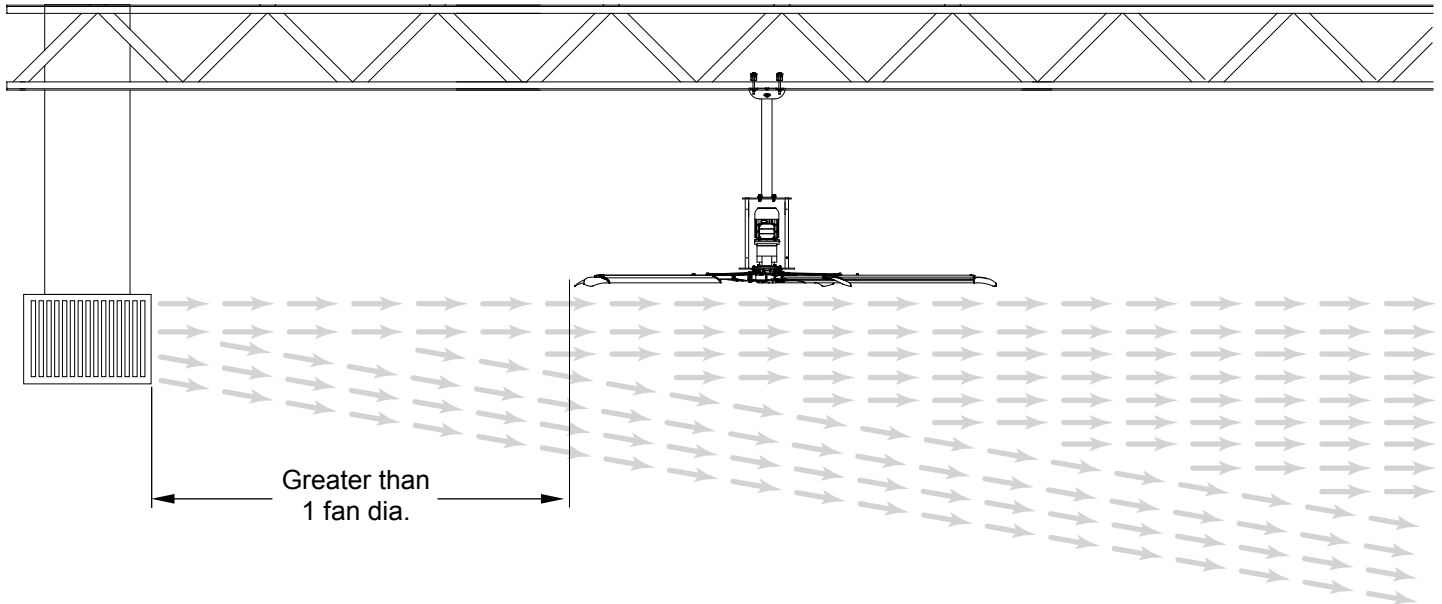

Placement of the Fan.
Click [here](#) to view the video

- Fans located at or below HVAC equipment must have a minimum clearance of greater than or equal to 2 fan diameters. See **Figure 3**.

Figure 3

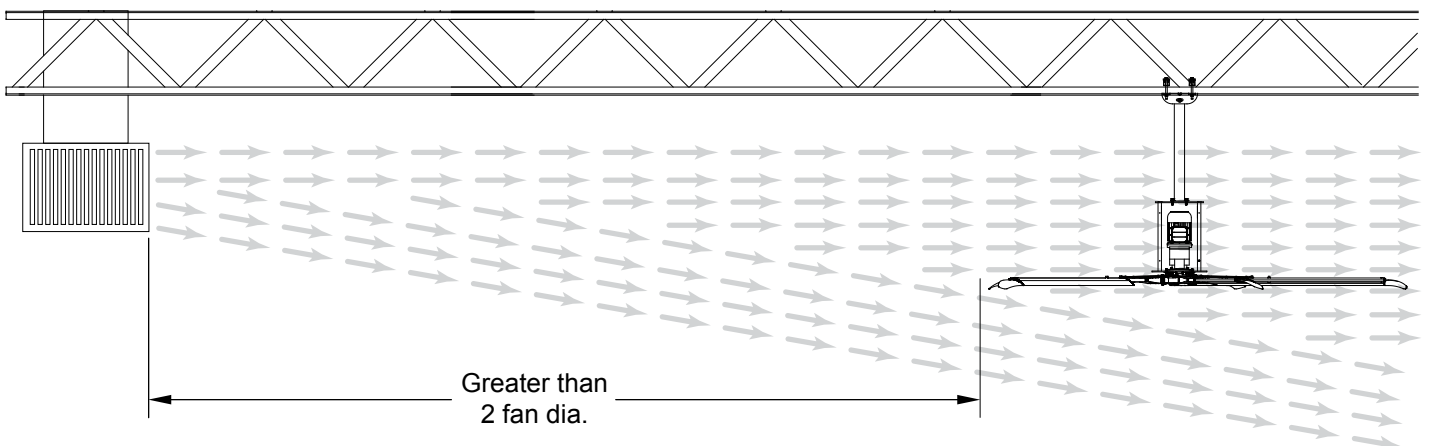

CLEARANCE FROM SOLID CONSIDERATIONS

For applications near solid obstructions, the HVLS fan must be installed at minimum distances. Fans located near solid obstructions, such as walls, racks, or columns greater than one foot wide should have a minimum distance of one half (1/2) fan diameter from the end of the blade.

Fans located above solid obstructions, such as racks, walls, etc. must have a minimum distance of greater than or equal to 1/2 fan diameter above the obstruction. The obstruction below must also be less than or equal to 1/4 fan diameter inside the fan blade arc. See **Figure 4**.

Figure 4

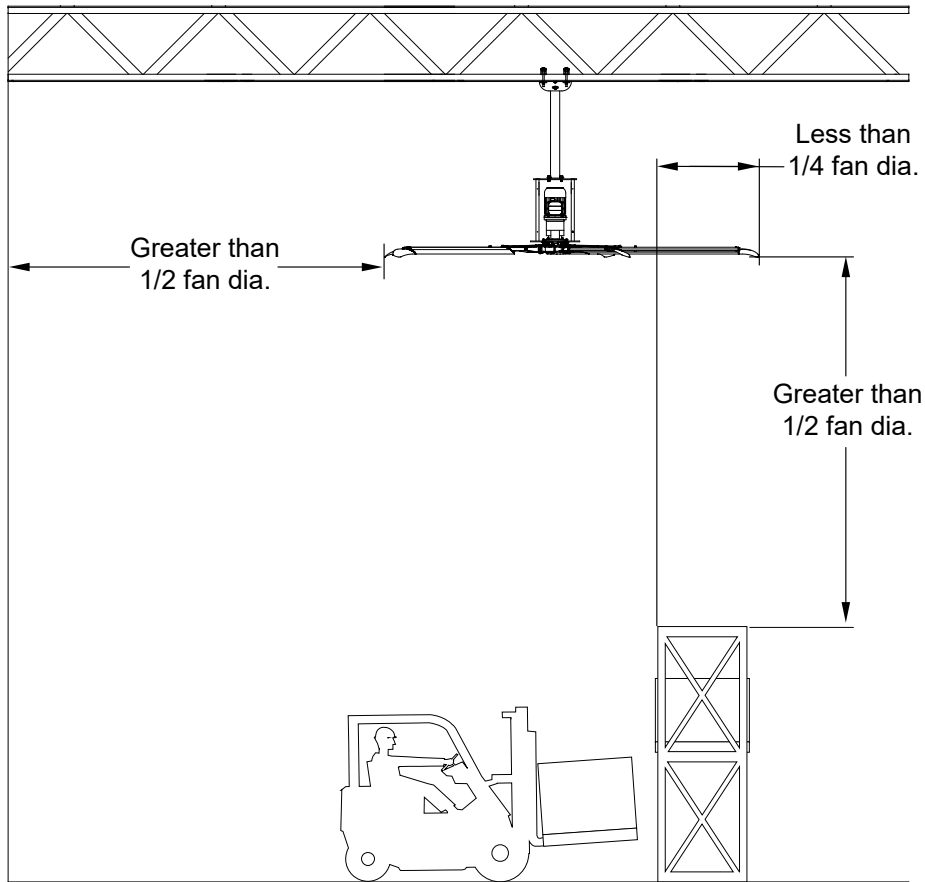

BUILDING STRUCTURE

For open structure roof designs, the fan should only be hung from either an I-beam or angle iron. Do not hang the fan from purlins, joists, or truss structures unless all of the following apply.

- The truss can handle the load of the fan.
- The bottom chords of the truss are larger than 5", but smaller than 10 1/2" combined.
- The fans are installed at the strongest point load on the truss.

If you have questions as to whether or not the truss can handle the fan load, you must consult a local structural engineer.

For solid beam or laminated wood beam mounting, use the laminated wood beam mounting kit available from 4FRONT.

Ensure the fan blade clearance meets the requirements shown in **Figure 1** through **Figure 5**.

NOTICE

Consult a professional engineer or registered architect for specific mounting concerns.

PLACEMENT AND SPACING

Consult your local distributor to help you plan the most efficient installation of your fans.

Ensure you place the fan so that fans are a minimum of 10' from any manned working surface (floor or mezzanine).

Ensure the fan blades do not extend into the exclusion zone. Extensions are available if you need them. See **Figure 1**.

Avoid mounting fans directly under lights or skylights to avoid a visual strobe effect.

Figure 5

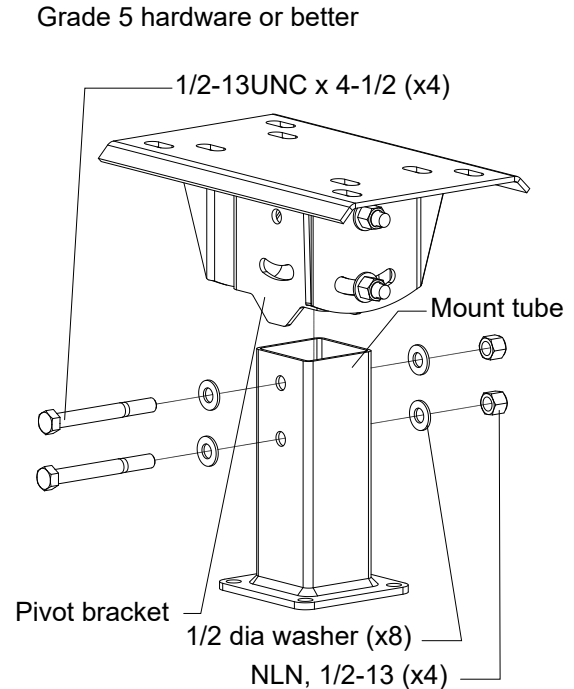

NOTICE

If the fan is part of a networked system, ensure placement is in accordance with the building layout. The fan network is located on the front panel of the Variable Frequency Drive (VFD) box.

Be sure to comply with all local and national codes during installation.

INSTALLATION

⚠ DANGER

Before installation, make certain the power is disconnected and properly locked out.

⚠ DANGER

Before installing the fan, read and follow the [Safety Practices beginning on page 8](#). Failure to follow these safety practices could result in death or serious injury..

For fans that will be subjected to high cross winds due to open bay doors or air conditioning diffuser ducts, the fan must be at least one fan diameter (as measured from the end of the winglet) from open bays or A/C ducts mounted below the blade plane or there must be at least two fan diameters (as measured from the end of the winglet) for A/C ducts mounted at or above the blade plane.

FAN MOUNT ASSEMBLY

1. Fasten the pivot brackets to the extension tube with ears outboard.
2. Leave the 1/2" dia. x 4-1/2" bolts and nylock nuts finger tight. See **Figure 6**.

Figure 6

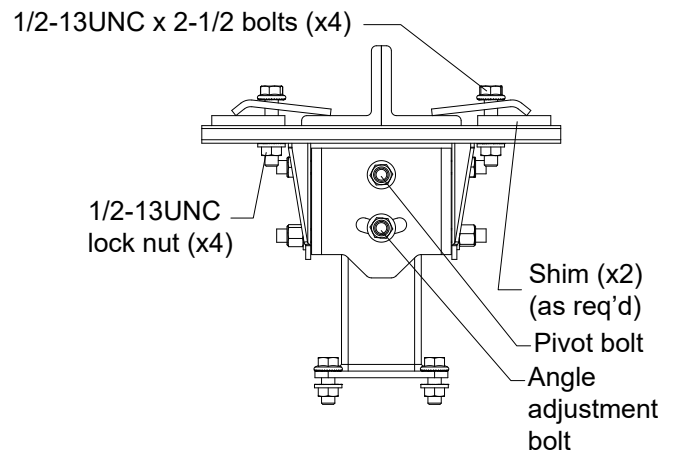

Mounting Options
Click [here](#) to view the video

INSTALL FAN MOUNT

If the building support beam is not level, ensure the proper fan clearance using the mounting information in [Installation Considerations on page 15](#) or add mounting extensions. See [Figure 1](#).

STANDARD I-BEAM

1. Locate the fan mount assembly on the bottom of the building support beam.
2. Align the mount assembly so that it is centered and square to the beam,
3. Orient the mount such that the pivoting axis is aligned with the building slope, if required.
4. Install the clamps.
5. Add shims as required for thick flange I-Beams.
6. Fasten the clamps using the supplied 1/2" dia. x 2-1/2" screws, lock nuts, and washers.
7. Torque to 44-48 lb-ft. See [Figure 7](#).

LAMINATED WOOD BEAM MOUNTING — OPTIONAL KIT 6018028

1. Attach the laminated wood beam brackets to the wooden beam using a minimum of four 1/2" dia. grade 5 thru bolts and self-locking nuts (not supplied).
2. Ensure the brackets are square to the bottom of the beam.
3. Attach the mount assembly to the laminated wood beam brackets using the supplied 1/2" dia. x 2-1/2" screws, lock nuts, and washers.
4. Torque to 44-48 lb-ft. See [Figure 8](#).

Figure 7

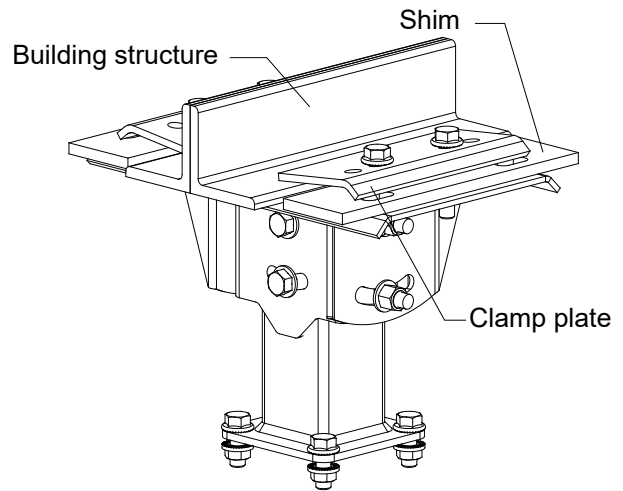
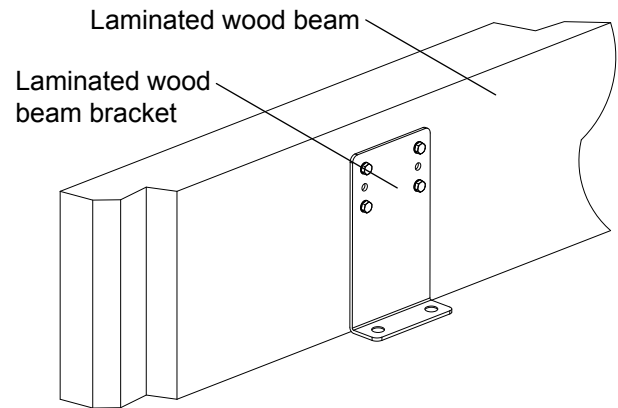

Figure 8



TRUSS MOUNT WITHOUT 4FRONT KIT

NOTICE

Do not span gaps larger than 96".

To span two trusses or purlins with a gap of 96" or less:

1. Span the gap using two 4" X 4" steel angle irons (not supplied). See **Figure 9**.
2. Connect through trusses with heavy-duty square washers and lock bolts/nuts (not supplied).
3. Torque to 44-48 lb-ft.

Figure 9

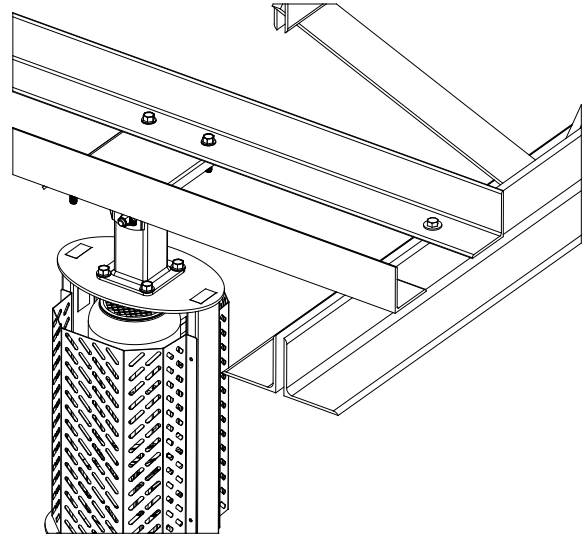

TRUSS MOUNT WITH 4FRONT KIT

1. Install the angle weldment and mounting plates using the supplied 1/2" grade 5 locking hardware. See **Figure 10**.
2. Torque to 44-48 lb-ft.
3. Locate the fan mount assembly on the bottom of the angle weldment. Align the mount assembly so that it is centered and square to the angle weldment. See **Figure 11**.

Figure 10

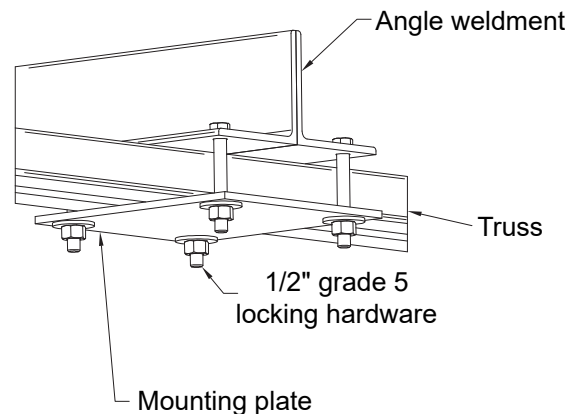
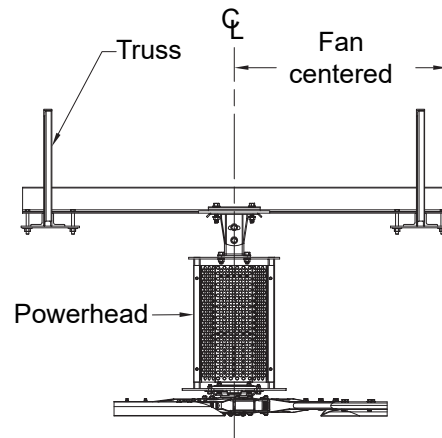

Figure 11



Z-PURLIN / C-CHANNEL INSTALLATION

CAUTION
 Only install HVLS fan on z-purlins with web height of 6" or larger, thickness of 14ga (.0747") or thicker, and no longer than 30'

1. Drill 9/16" holes in the center of the z-purlin. Use the supplied fan mount backer plate as a template. See **Figure 12**.
2. Using the supplied 1/2" bolts and nut, fasten the mount and the mount backer to the z-purlin using the 9/16" drilled holes. See **Figure 13**.
3. Repeat for opposite z-purlin.
4. Trim fan support weldment to required length.
5. Drill holes in fan support weldment to match mounting hole on mount.
6. Fasten the fan support weldment to the mount using the supplied 1/2" bolts and nuts and repeat for the opposite z-purlin. See **Figure 13**.

Figure 12

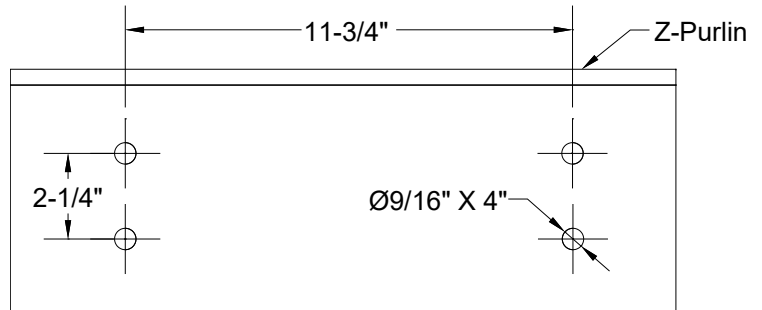

Purlin Length	Minimum Web Height
<10'	6"
10-15'	7"
15-20'	9"
25-28'	10"
28-30'	12"

Figure 13

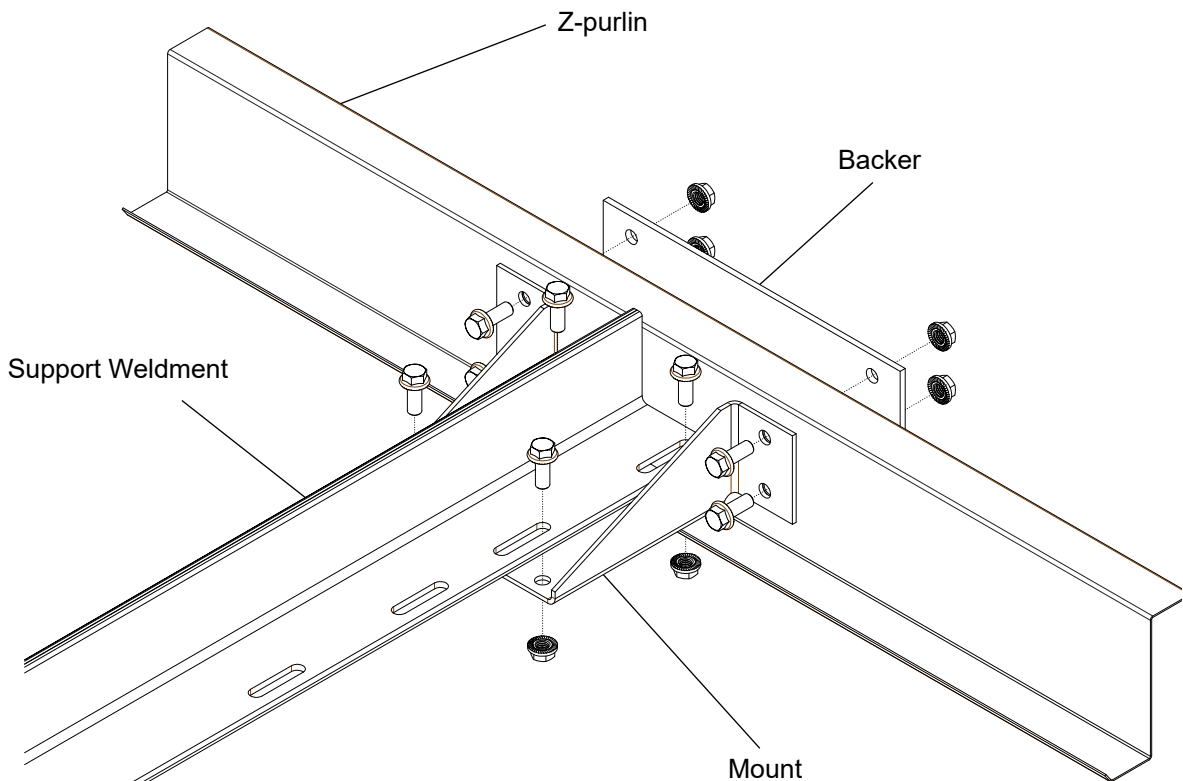

INSTALL THE POWER HEAD (MOTOR/GEARBOX ASSY)

The power head may be oriented as required for aesthetics or commonality.

Leave the protective bumper on the bottom of the power head assembly until the power head is mounted in place.



Mounting the Powerhead
Click [here](#) to view the video.

1. Using a powered lift, orient the power head with the blade hub down.
2. Block the motor as required for installation using the bottom of the frame assembly.

Do not support it using the hub or hub cap.

3. Raise the power head up until it contacts the bottom of the fan mount assembly. See **Figure 14**.
4. Use the supplied hardware to attach the powerhead to the bottom of the mount assembly. See **Figure 15**.
5. Immediately attach the safety cable. The torque rating must be 44-48 lb-ft. See **Figure 16**.

- a. Slide two of the supplied 1/4" dia. cable clamps over each end of the cable spaced 6" apart.
- b. Slide the ends through the cable clamps.
- c. Make sure the cable goes through the motor frame.
- d. Securely tighten the clamp fasteners.
- e. Make sure the u-bolts are over the free ends of the cable.
- f. Ensure the safety cable does not interfere with the fan motor housing.
- g. Trim any excess cable or wrap the cable multiple times to ensure the cable does not interfere with the fan motor housings or hub.

Figure 14

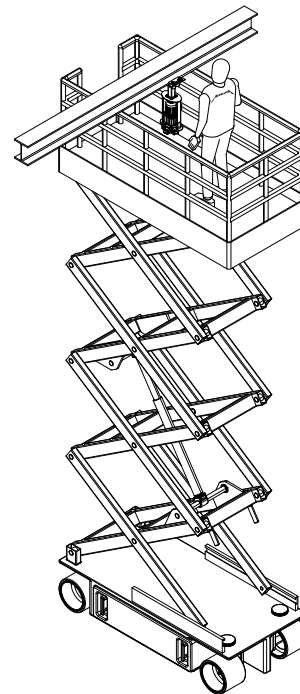
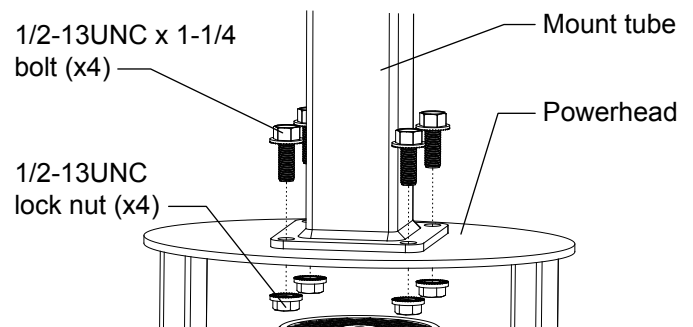

Figure 15



INSTALL THE GUY WIRES

Guy wires are designed to constrain lateral movement of the fan when it is operating. This movement may be due to impacts on the fan or winds impinging on the blades causing the fan to sway.

NOTICE

Failure to attach guy wires may result in loss of warranty.

The longest extension allowed is 20'. Any extensions longer than 12' must use the secondary guy wire kit (6020303 — standard and 6020304 — stainless steel).

Consult a professional engineer or registered architect for specific mounting concerns.

WARNING

*If you have used a mounting extension, make sure you use the longer guy wires accompanying the extension. Ensure the angle formed by the guy wire with the roof structure is less than 45°. See **Figure 17**.*

Avoid all sharp edges or corners to reduce fatiguing and fraying of the guy wires.

Failure to attach guy wires may result in severe injury or death.

1. Adjust the turnbuckles to their longest position.
2. Attach the quick link with the attached turnbuckle to the fan as shown in **Figure 18**.
3. Repeat for all four quick links.
4. Attach one end of the guy wire to the building structure.

Figure 16

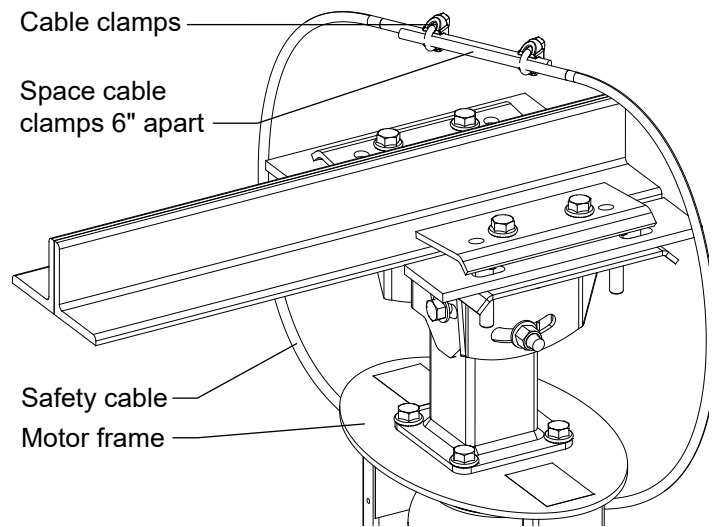

Figure 17

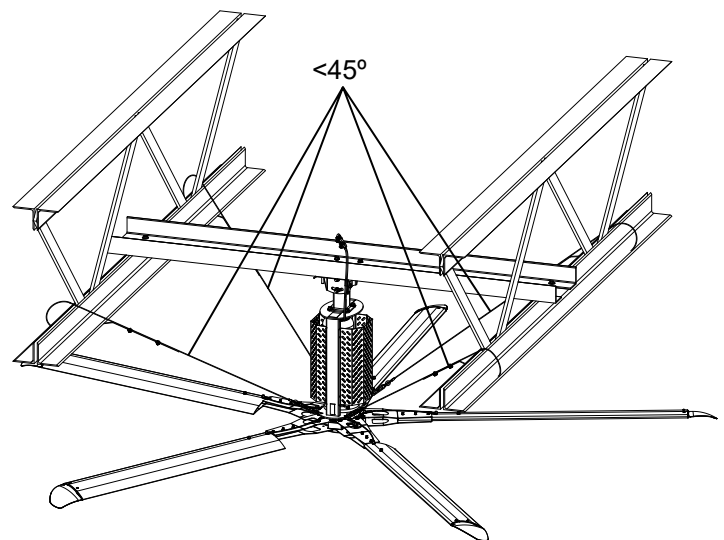
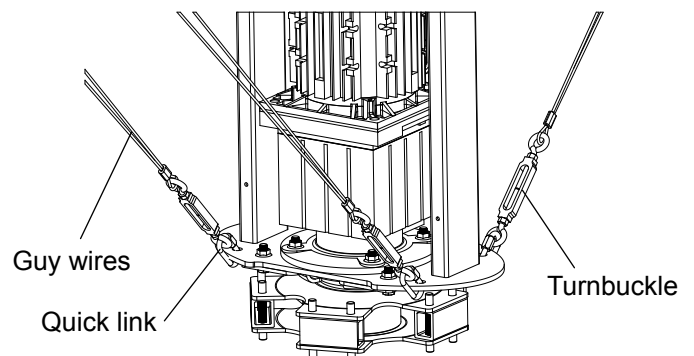

Figure 18



Installation

5. Ensure the structure has sufficient strength to withstand the wire tension.
6. Repeat for all four guy wires.
 - a. Slide two of the supplied 1/8" dia. cable clamps over one end of the wire.
 - b. Feed that end of the wire through the building structure and back through the clamp fasteners.
 - c. Securely tighten the clamp fasteners so they cannot slip.
 - d. Make sure the u-bolts are over the free end of the cable.
7. Individually tighten the turnbuckles on each cable until it is taut and the power head unit hangs plumb.

Use a spirit level to verify the power head unit hangs plumb.
8. Tighten the pivot and angle adjustment bolts on the fan mount.
9. Torque to 44-48 lb-ft. See **Figure 19**.

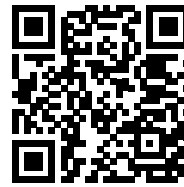

Install Guy Wires
Click [here](#) to view the video

Figure 19

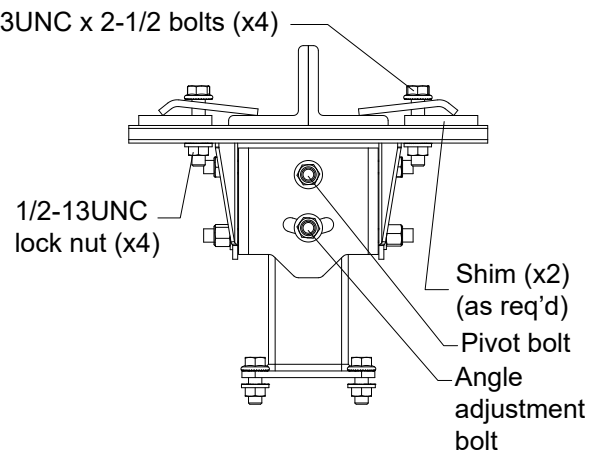

INSTALL THE VFD BOX

Verify the voltage and phase before mounting the box. Ensure the voltage from the building source wiring matches the voltage listed on the VFD box.

▲ WARNING

The VFD Box must be installed outside and a safe distance from the blade diameter for service.

▲ WARNING

Do NOT bypass the VFD by wiring incoming voltage directly to the motor. This could result in damage and increase the safety risk.

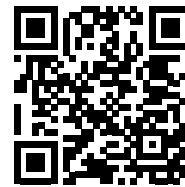

Installing the VFD Enclosure
Click [here](#) to view the video

NOTICE

The maximum length of the cable between the VFD box and the motor is 150 linear feet.

Do not run motor cables in the same conduit as the input voltage.

Do not run the motor cables in the same conduit as other motor cables.

If you mount multiple VFD panels in the same location, tie the grounds in series.

1. Mount the VFD box outside of the fan blade arc.

Orient the box so that the front panel is accessible and visible with the connectors on the top of the panel.

2. Route the fan S.O. cable from the fan to the VFD box and check to make sure the cable is supported throughout its routing.
3. Route the supply power from the building source to the VFD box.
4. Wire the VFD box in accordance with the [Electrical Schematics on page 32](#).

NOTICE

For 3 blade models, skip to [Install the Blades on page 29](#).

INSTALL THE MOTOR COVER (5-BLADE MODELS ONLY)

1. Check that the motor S.O. cable has been routed to the VFD box and ensure it is secured.
2. Locate each motor cover and install the cover fasteners. Do not over-tighten the fasteners. See [Figure 20](#).

Figure 20

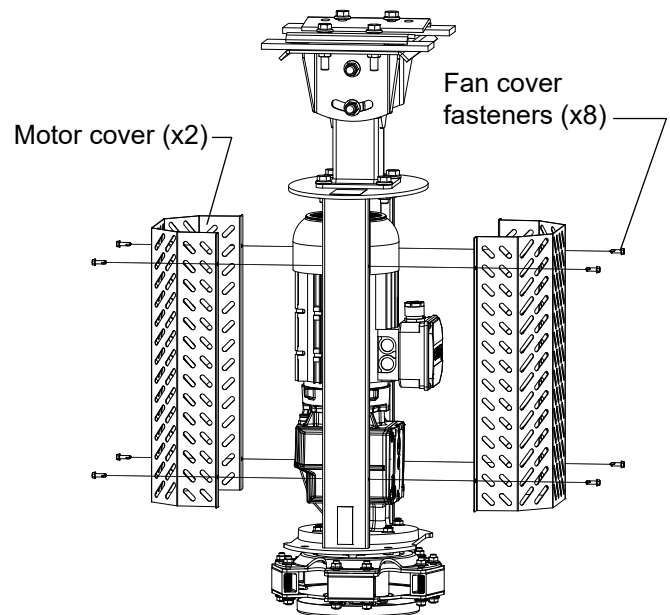

INSTALL THE BLADES

▲ WARNING

To reduce the risk of personal injury, do not bend the blade brackets when installing the brackets or cleaning the fan.

Do not insert foreign objects in between the rotating fan blades.

Blade assemblies come pre-assembled from the factory. **Do not attempt to disassemble them.**

The hub assembly has special blade retention lock nuts pre-assembled to the hub. Remove them and use them to mount the assemblies as shown in the steps below.

Use only the factory supplied lock nuts provided for blade mounting.

1. With the blade oriented so that the blade retention lanyard is on top, support the blade assembly from below.
2. Orient and guide the assembly onto the top attachment studs on the hub assembly.
3. Spread the strut arms slightly onto the upper studs.
4. Angle the blade upward as needed onto the studs. See **Figure 21**.
5. Still supporting the blade assembly, rotate the blade assembly down and allow the bottom blade strut to ride up and over the bottom attachment studs on the hub assembly. See **Figure 22**.

NOTICE

Do not lean on the blade. Damage to the strut may occur.

6. Install the blade retention lock nuts.
7. Hand tighten the nuts to ensure the strut arms are firmly pressing against the hub.

Figure 21

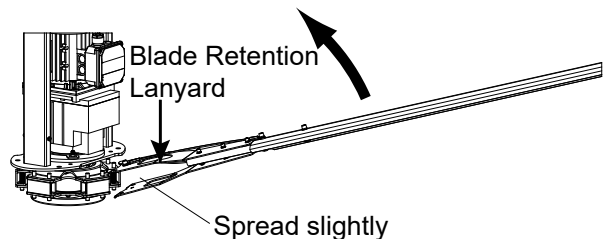
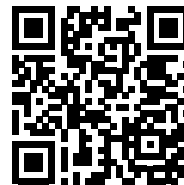
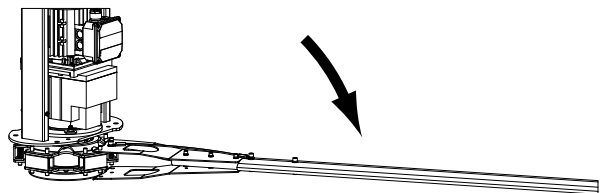

Figure 22



Installing the Blades
Click [here](#) to view the video.

Installation

- Torque the blade retention nuts to 24-28 lb-ft. See **Figure 23**.
- Repeat steps 1 through 8 for each blade assembly.

Figure 23

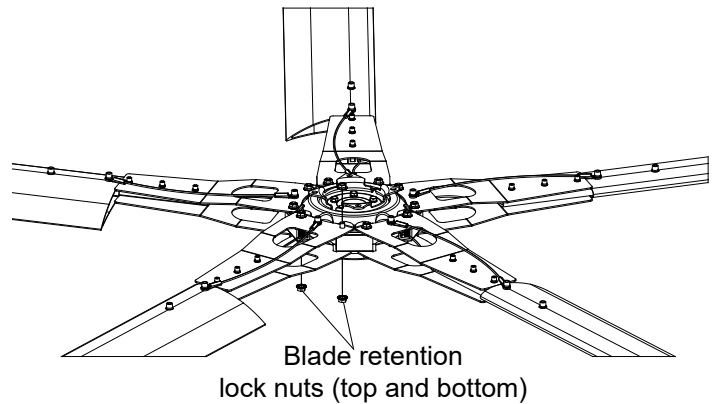

VERIFY CLEARANCE AND CABLE TENSION

- Rotate the fan by hand and observe the clearance of each blade from its closest obstruction.
- If necessary, reposition the fan.

NOTICE

Blade tips droop when not in operation and rise when in operation.

- Verify the guy wire tension by attempting to move the power head in any horizontal direction.

If you detect movement, re-tension the guy wires.

- Lock the individual turnbuckles using the stop nut on each.
- Secure the turnbuckle with the turnbuckle strap. See **Figure 24**.

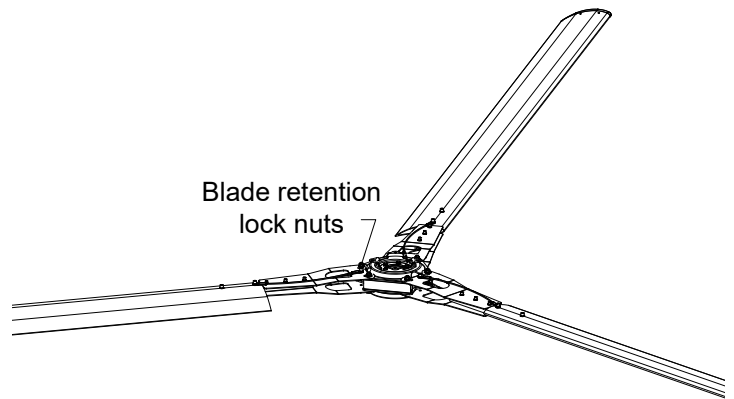

Figure 24

INSTALL REMOTE CONTROL

NOTICE

Do not over-torque the mounting screws.

Damage to the display screen may occur if you over-torque the mounting screws.

It is your responsibility to torque the screws properly.

- Mount the touchscreen remote 53" above the floor to the factory supplied junction box inside the building

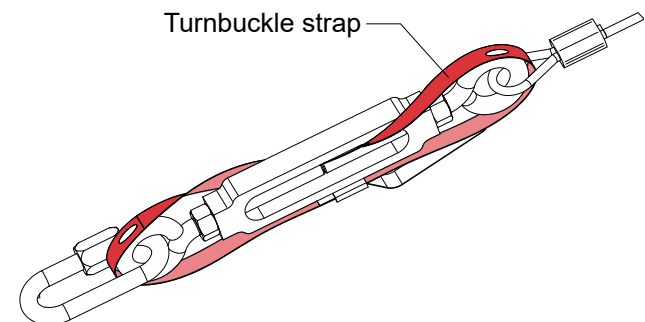

Mount the touchscreen as close to the fan assembly as practical. Direct line of sight is preferred. See **Figure 25**.

NOTICE

For remote signal (blue) CAT5e cable runs exceeding 1,000 feet, consult the factory.

NOTICE

The Blue CAT5e cable has terminated ferrules at the remote end.

PROTECT these ferrules during cable routing.

2. Route the remote signal (blue) cable (6015651) from the top of the VFD box through the hole in the factory supplied junction box.
3. Wire the four leads of the remote signal (blue) cable to the orange connector of the touchscreen remote control.
4. Neatly coil the excess blue cable and secure it near the VFD box.
5. Using the supplied fasteners, mount the touchscreen to the junction box.

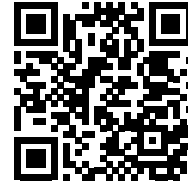

Install Remote Control
Click [here](#) to view the video.

Figure 25

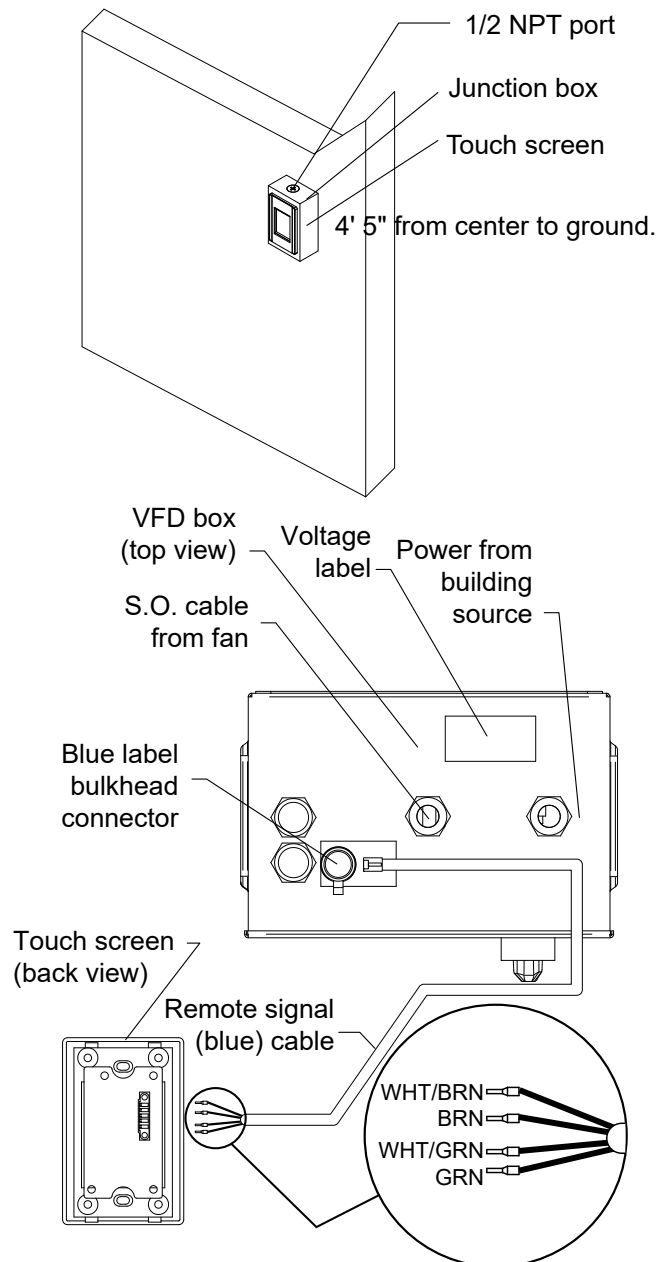

ELECTRICAL SCHEMATICS

⚠ DANGER

Before doing any electrical work, make certain the power is disconnected and properly locked out and tagged out.

Failure to do so may result in death or serious injury.

All electrical troubleshooting and repair must be done by a qualified technician and meet all applicable codes.

Do not route control wiring for any other device through this control box.

Ensure the voltage and phase of the incoming power agrees with the label on the top of the VFD box and fan.

Be certain the power is off when wiring to the control box.

Failure to do so may result in electrical shock, death, or serious injury.

1PH WIRING DETAILS

Figure 26

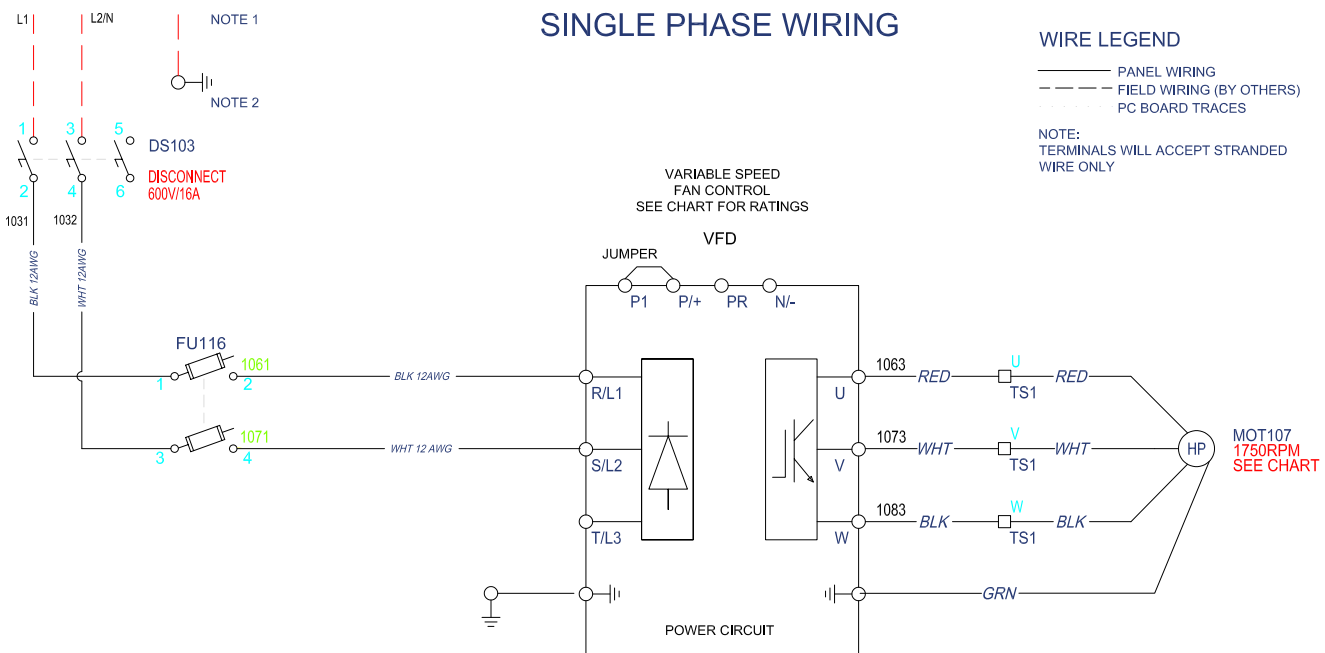

NOTICE

Terminals will accept stranded wire only.

SIZING CHART				
	8 FT - 24 FT 3-BLADE		8 FT - 20FT 5-BLADE	24FT 5-BLADE
	6025193 6026310 6026973	6025278 6026311 6026973	6024603 6024498 6026304 6026971	6024606 6024499 6026307 6026970
VOLTAGE	110-120V/1PH/ 50 60HZ	200-240V/1PH/ 50 60HZ	200-240V/1PH/ 50 60HZ	200-240V/1PH/ 50 60HZ
FLA	3.68A	3.68A	5A	6.79A
FUSE	KTKR15	KTKR10	KTKR15	KTKR20
MOTOR	1.0HP, 2.9 FLA @230V/60HZ	1.0HP, 2.9 FLA @230V/60HZ	1.5HP, 4.0 FLA @230V/60HZ	2HP, 5.43 FLA @200-240V/60Hz
VFD	100-120V/1PH 1HP/0.75KW/4.2A	200-240V/3PH 2HP/1.5KW/7.0A	200-240V/1PH 2HP/1.5KW/7.0A	200-240V/1PH 2HP/1.5KW/7.0A
O/L	3.38A	3.38A	4.6A	6.24A

- Field wiring is to be a minimum 14AWG, 600V, 90°C.
- The safety ground must be connected to the earth ground rod via the plant ground or bus bar. Grounding points must comply with national and local industrial safety regulations and/or electrical codes.

3PH WIRING DETAILS

Figure 27

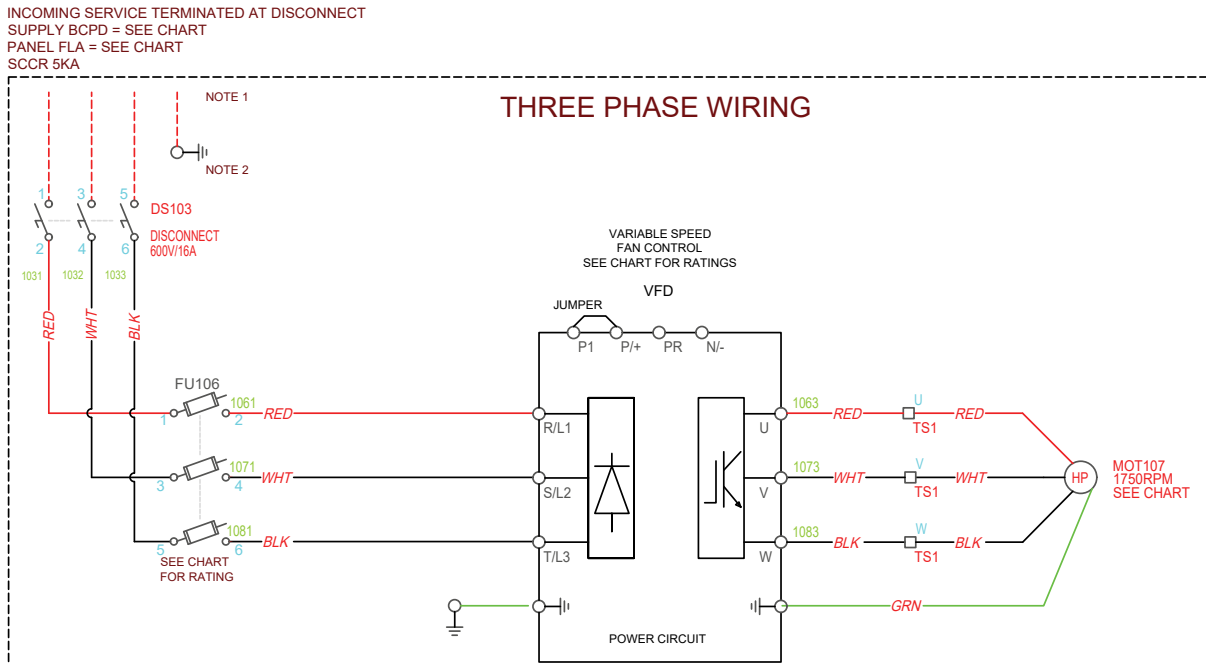

NOTICE
 Terminals will accept stranded wire only.

SIZING CHART						
	8FT-24 FT 3-BLADE			8FT-20 FT 5-BLADE		
	6025279 6026312 6026969	6025280 6026313 6026966	6027183 6026925	6024604 6024496 6026305 6026968	6024605 6024494 6026306 6026965	6024443 6026926
VOLTAGE	200-230V/3PH/ 50 60HZ	380-480V/3PH/ 50 60HZ	380-480V/3PH/ 50 60HZ	200-230V/3PH/ 50 60HZ	380-480V/3PH/ 50 60HZ	380-480V/3PH/ 50 60HZ
FLA	3.68A	1.84A	1.84A	5A	2.5A	2.5A
FUSE	KTKR10	KTKR5	KTKR5	KTKR10	KTKR5	KTKR5
MOTOR	1.0HP, 2.9FLA @ 230V/60HZ	1.0HP, 1.47 FLA @ 460V/60HZ	1.0HP, 1.47FLA @460V/60HZ	1.5HP, 4.0FLA @ 230V/60HZ	1.5HP, 2.0FLA @ 460V/60HZ	1.5HP, 2.0FLA @ 460V/60HZ
LINE REACTOR	N/A	N/A	6010722	N/A	N/A	6010718
VFD	200-240V/3PH 2HP/1.5KW/ 7.0A	380-480V/3PH 2HP/1.5KW/ 3.6A	360-480V/3PH 2HP/1.5KW/ 3.6A	200-240V/3PH 2HP/1.5KW/ 7.0A	360-480V/3PH 2HP/1.5KW/ 3.6A	360-480V/3PH 3HP/2.2KW/ 5.0A
O/L	3.38A	1.69A	1.69A	4.6A	2.3A	2.3A

SIZING CHART			
24 FT 5-BLADE			
	6024607 6024497 6026308 6026967	6024608 6024495 6026309 6026964	6024442 6026927
VOLTAGE	200-240V/3PH/50 60HZ	380-480V/3PH/50 60HZ	380-480V/3PH/50 60HZ
FLA	6.79A	3.4A	3.4A
FUSE	KTKR10	KTKR5	KTKR5
MOTOR	2HP, 5.43FLA @ 230V/60HZ	2HP, 2.72FLA @ 460V/60HZ	2HP, 2.72FLA @460V/60HZ
LINE REACTOR	N/A	N/A	6010719
VFD	200-240V/3HP 2HP/1.5KW /7.0A	360-480V/3PH 2HP/1.5KW/3.6A	360-480V/3PH 3HP/2.2KW/5A
O/L	6.24A	3.13A	3.13A

- Field wiring is to be a minimum 14 AWG.600V, 90°C.
- The safety ground must be connected to the earth ground rod via the plant ground or bus bar. Grounding points must comply with national and local industrial safety regulations and/or electrical codes.

VARIABLE FREQUENCY DRIVE

Figure 28

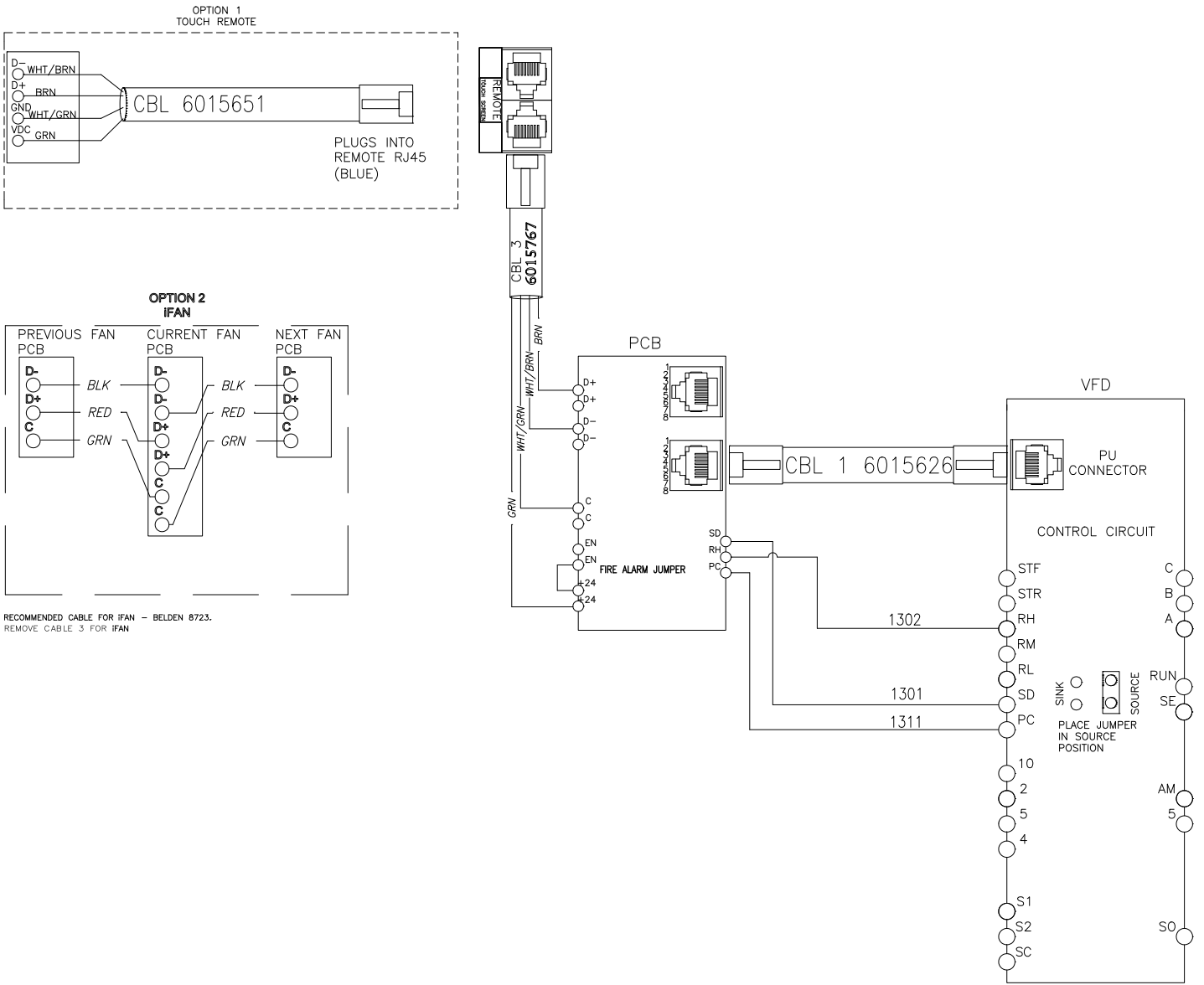

MULTI FAN WIRING DETAILS — OPTIONAL

Figure 29

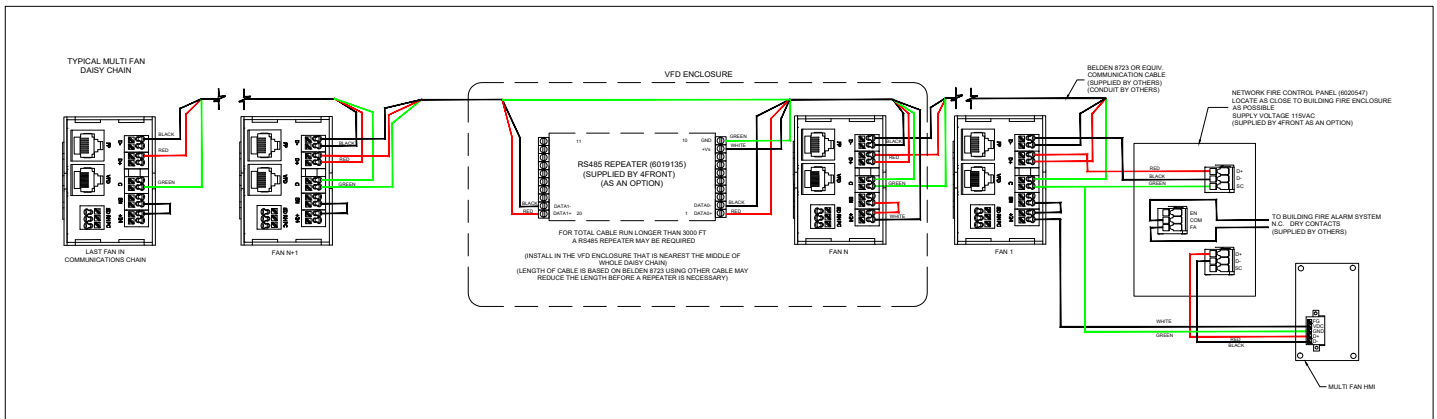

- The recommended cable for multi-fan and iFAN is Belden 8723.



Download this drawing

Click [here](#) to view this drawing.

IFAN WIRING DETAILS

Figure 30

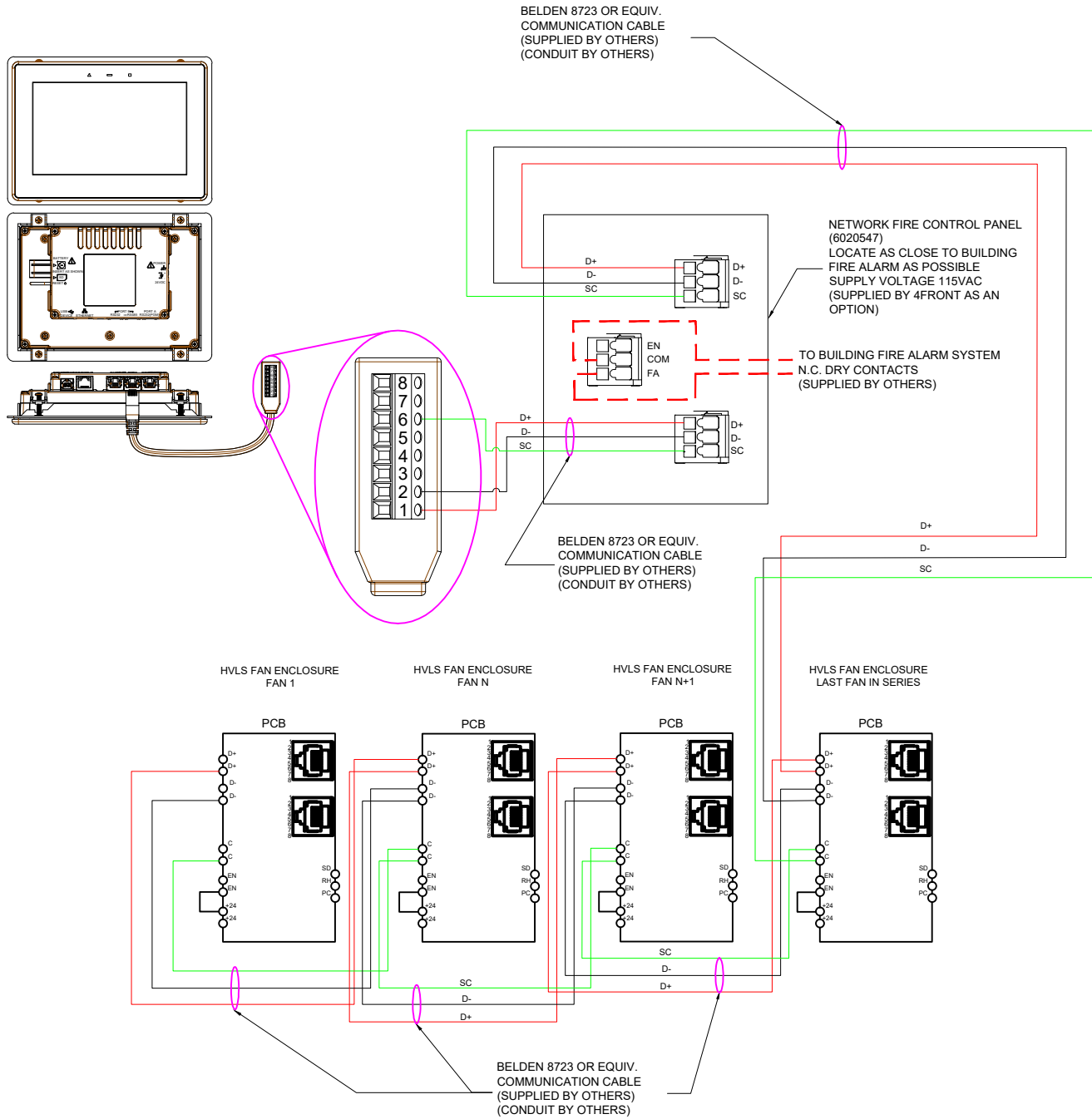

TEMP/HUMIDITY CONTROL WIRING DETAILS — OPTIONAL

Figure 31

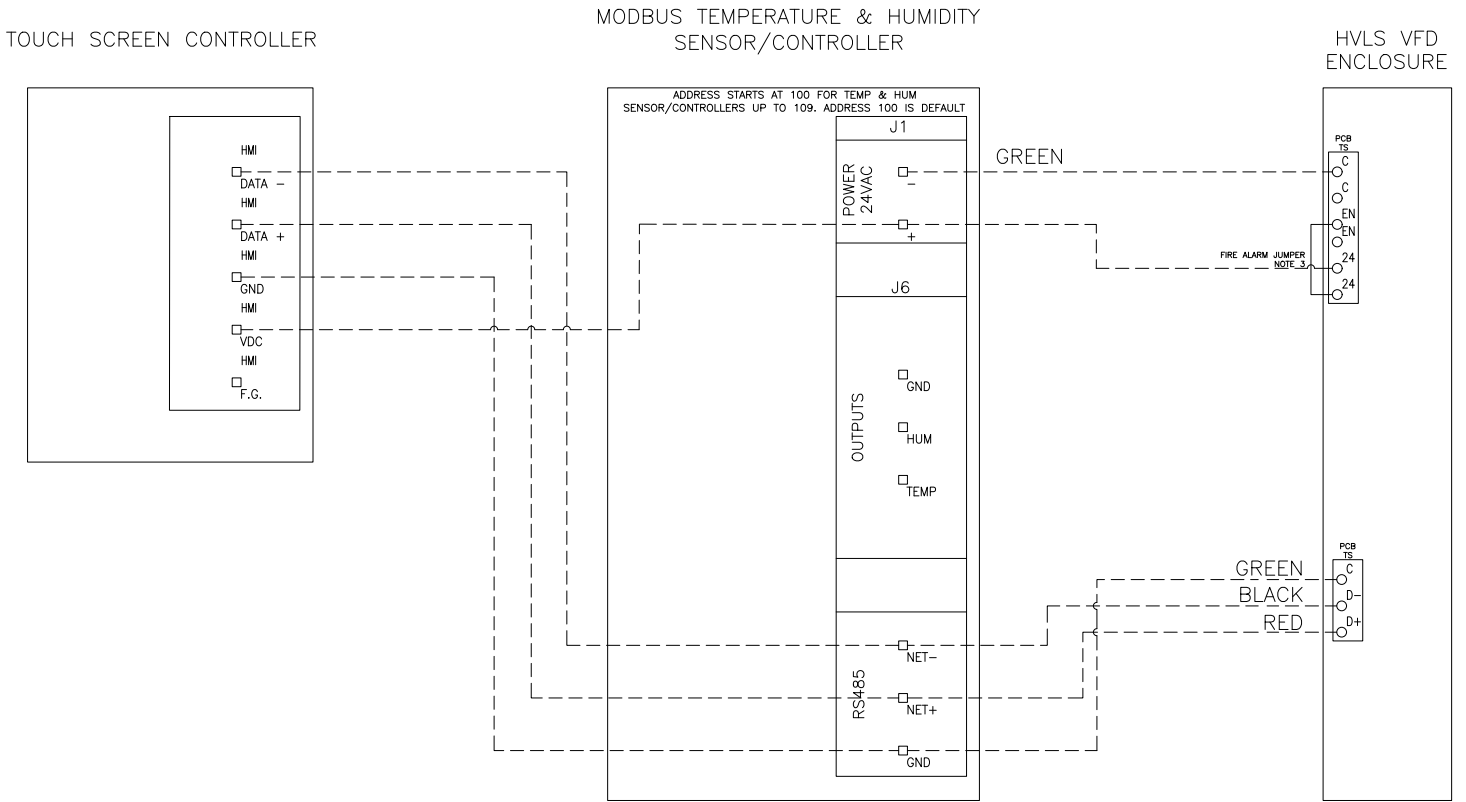

FIRE CONTROL SYSTEM FAN SHUTDOWN — OPTIONAL

This fan includes a fire alarm option. This option allows the fan to be shut down by the fire control system in case of an emergency.

NOTICE

Ensure the fire alarm jumper is in place or the building fire control system is connected and the jumper removed.

The normally closed (NC) contacts must be dry contacts. They open in the event of an active alarm.

ENABLE THE FIRE CONTROL SHUTDOWN OPTION

The fire control system fan shutdown option is not enabled when shipped. To enable the shutdown option:

1. Remove the jumper between enable (EN) and (24).
2. Replace the jumper with a set of dry, normally closed contacts. See the schematics for the optional fire control panels. See [Fire Control System Fan Shutdown Panel — Standard Installation \(6015291\)](#) on page 41.

TEST THE FIRE CONTROL SHUTDOWN OPERATION

To test the fire control system fan shutdown operation:

1. Remove the wire from the NC contact at the building fire control panel. See **Figure 32**. The fan should coast to a stop.

NOTICE

If you leave the jumper installed, the fan will not shut down due to the fire control system contacts.

Figure 32

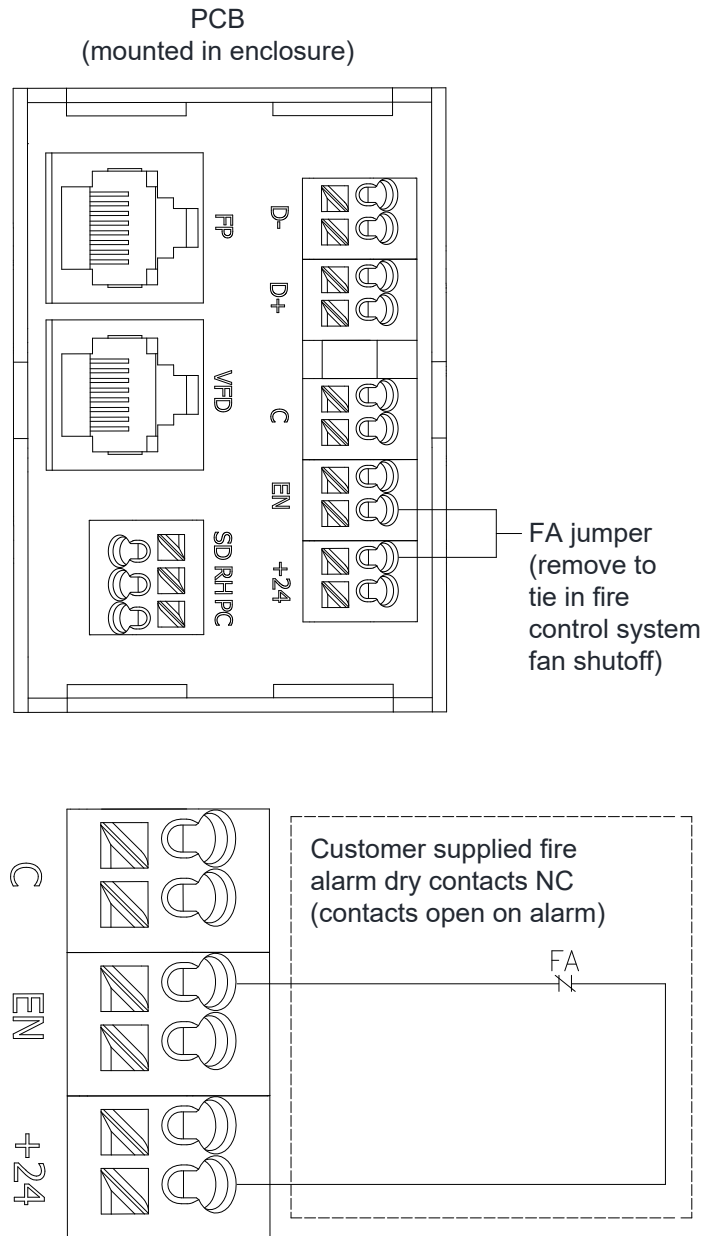

FIRE CONTROL SYSTEM FAN SHUTDOWN PANEL — NETWORK INSTALLATION (6020547)

Figure 34

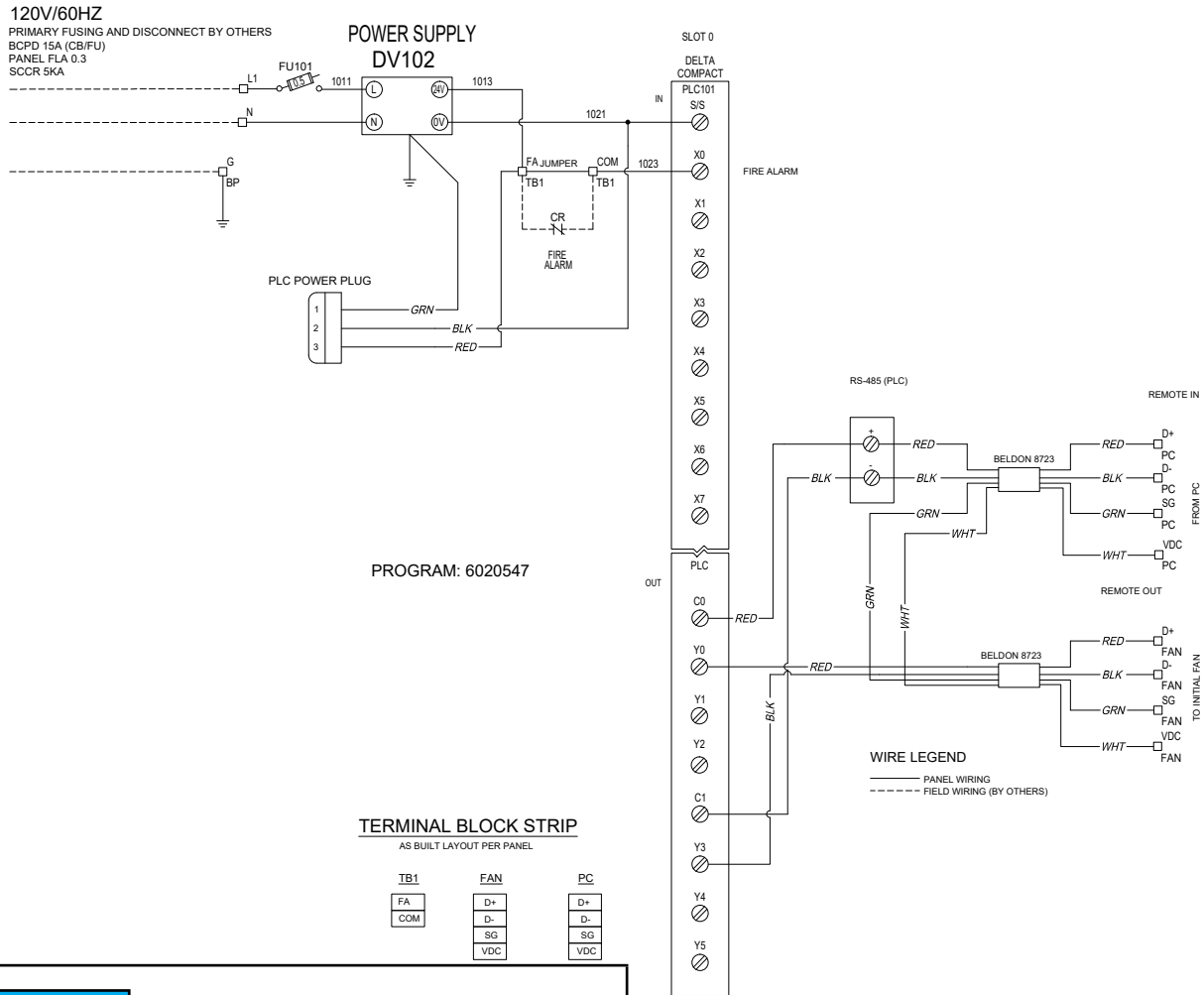

NOTICE
 Terminals will accept stranded wire only.

Wire Color/Gauge (NFPA) (Unless otherwise specified)		
120 VAC	#16	RED
Neutral	#16	WHT
Ground		GR
24 VDC	#18	BLU
24V COM (0VDC)	#18	BLU/WHT
12 VAC/VDC	#18	VIO
12V COM	#18	VIO/WHT
DRY UNPOWERED	#18	YLW

550-600V SUPPLY WIRING DETAILS — OPTIONAL

To connect the 480V fan to a 500-600V building supply, you must install a step down transformer assembly (6017277) between the power supply and the VFD enclosure. The wiring (by others) must be 600V rated 14 awg. All wiring must be installed in accordance with any national, state, or local code requirements.

The transformer assembly is rated for one single fan load only. Each fan must have its own step down transformer assembly.

1. Locate and mount the step down transformer outside the blade arc and near the VFD enclosure.
2. Route the supply power from the building source to the step down transformer.
3. Follow the VFD installation instructions using the power from the step down transformer as the power source.

Figure 35

575–600V/3 ϕ /60HZ

INCOMING SERVICE TERMINATED AT DISCONNECT
 BCPD 15A (CB/FU)
 PANEL FLA 6
 SCCR 5KA

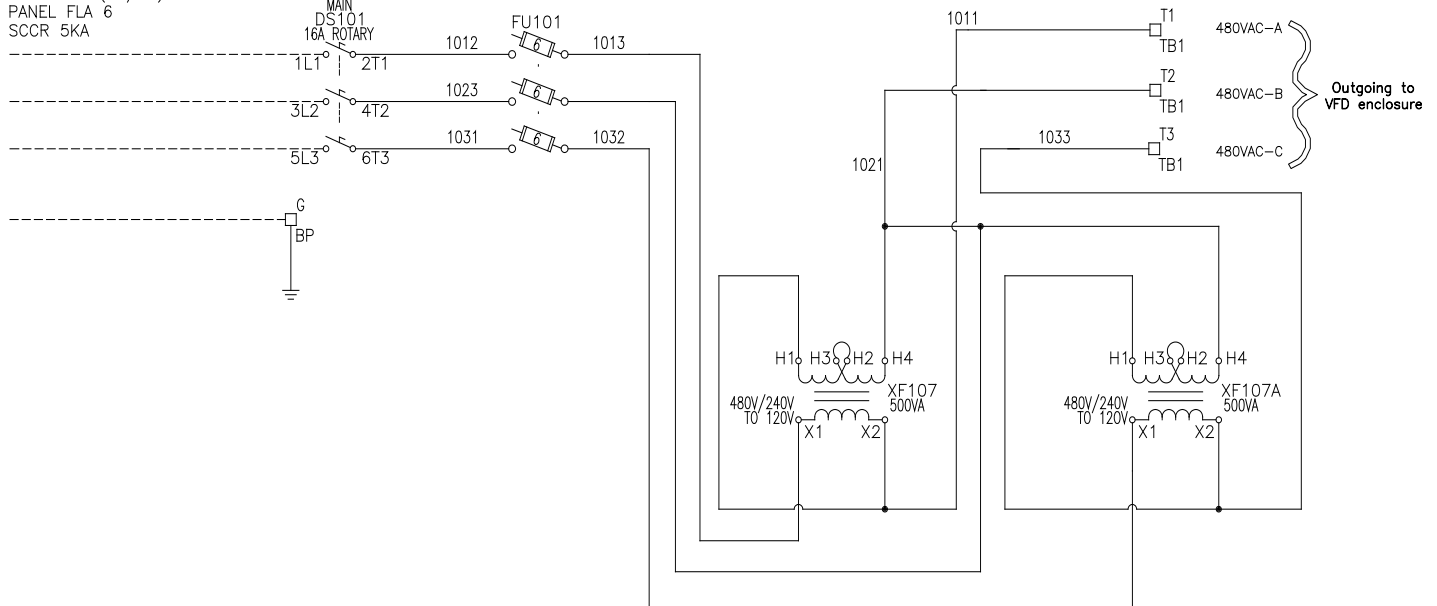

HMI SETUP

The Human Machine Interface (HMI) program controls up to a total of six fans. The program also allows the use of two types of accessories:

- Temperature Control
- High Wind Shutdown (anemometer)

Both accessories can be used with a single fan configuration. If the program is configured for multiple fans, you can only use the anemometer.

Once you complete the installation, the initial touchscreen control prompts you to configure your fan system. Follow the prompts on the HMI screen to complete these tasks.

DEFINE THE NUMBER OF FANS

1. Press the number of fans (1-6) the HMI will control. See **Figure 36**.

The number you selected changes to green.

SET THE DIAMETER OF THE FANS

NOTICE

The fan size is on the front of the VFD enclosure, the fan shipping container, and the blade shipping carton.

1. Press the left or right arrow to select the fan for which you want to set the diameter.
2. Press the up or down arrow to select the diameter for the selected fan. See **Figure 37**. Repeat steps 1 and 2 until you have set the diameter for all fans, and then advance to the next screen.
3. Verify that the sizes displayed are correct. See **Figure 38**. If so, press the right arrow.

Figure 36



Figure 37



Figure 38



ENABLE THE TEMPERATURE CONTROL OPTION (OPTIONAL)

NOTICE

The Temperature Control options require the use of an optional temperature sensor (Std: 6013861 or 4X: 6016700). The 4X option should only be used if the temperature sensor part number 6016700 is being used.

If you chose a single fan for the Fan Quantity on the first screen, the Enable Temperature Control screen displays.

1. Press **Yes** to enable the temperature control.

OR

Press No to disable.

2. Press the right arrow to continue. See **Figure 39**.

If you enable Temperature control, the temperature settings screen displays.

SET THE TEMPERATURE SETTINGS

1. Press **C** for Centigrade or **F** for Fahrenheit.
2. Press **Yes** if you are using a NEMA 4X temperature sensor; otherwise, press No. See **Figure 40**.

Figure 39



Figure 40

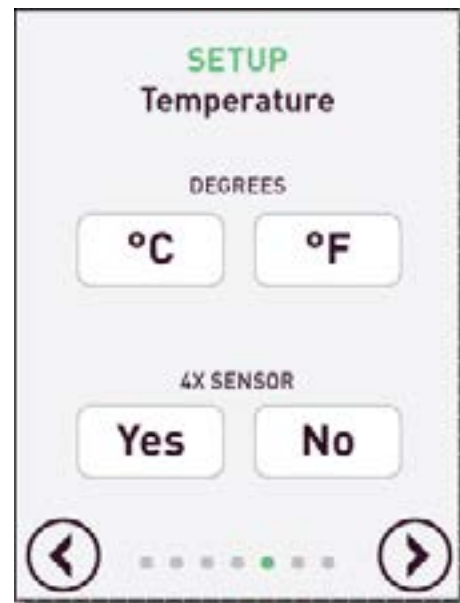

ENABLE THE WIND CONTROL OPTION

NOTICE

The Wind Control option requires the use of an anemometer supplied by 4FRONT.

1. Press **Yes** to enable the wind shutdown option; otherwise press **No**.

The option you selected changes to green. See **Figure 41**.

If you enable Wind Control, the Wind Unit screen displays.

SET THE UNIT OF WIND SPEED

NOTICE

The maximum speed and duration is set at the factory. If you want to change these parameters, you must contact the factory.

1. Press one of the following wind speeds:
 - MPH for miles per hour
 - KM/H for kilometers per hour
 - Knots for nautical miles per hour
 - M/S for meters per second

The dot next to your selection changes to green. See **Figure 42**.

CORRECT ERRORS DURING HMI CONFIGURATION

If you make an error when configuring the HMI program, you can go back to the Main setup screen to correct it. To access the Main screen:

1. Press the menu icon in the bottom left-hand corner of the screen.
2. Press the setup icon.
3. Enter the passcode (default 1111). The setup screen displays.

Figure 41



Figure 42

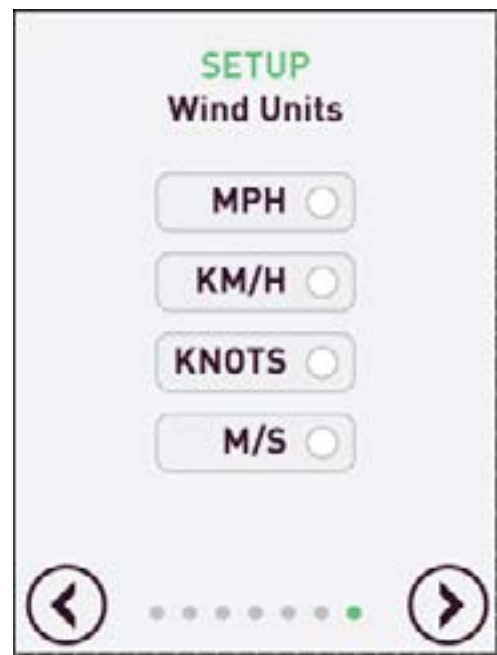

POST CONFIGURATION TASKS

After you configure the HMI program for your location, you should:

1. Operate the fan using the [Operating Instructions on page 48](#).
 2. Check the fan for proper rotation direction, stability, and noise level.
 3. Train authorized personnel how to use the fan using the [Operating Instructions on page 48](#).
-

TEMPERATURE CONTROL INSTALLATION — OPTIONAL

1. Mount the temperature control unit to the factory supplied junction box. The junction box is inside the building 60" above the floor. See [Temp/Humidity Control Wiring Details — Optional on page 39](#).
-

WIND CONTROL INSTALLATION — OPTIONAL

NOTICE

The Wind Control option requires the use of an anemometer supplied by 4FRONT.

1. Attach a 3/4" schedule 40 pipe (1.06" dia.) or 1" dia. structural pipe fitting to the outside of the structure so that it protrudes no less than 24" above the highest peak of the structure. This hardware is supplied by others.
2. Mount the wind speed/direction sensor to the pipe. You can pass the data cable through the center of the mounting pipe or the outside of the mounting pipe.
3. Route the data cable and terminate it at the VFD box.

If a longer data cable is required, use Belden 8723 or equivalent to extend the length.

OPERATING INSTRUCTIONS

FAN CONTROL SCREEN

Figure 43

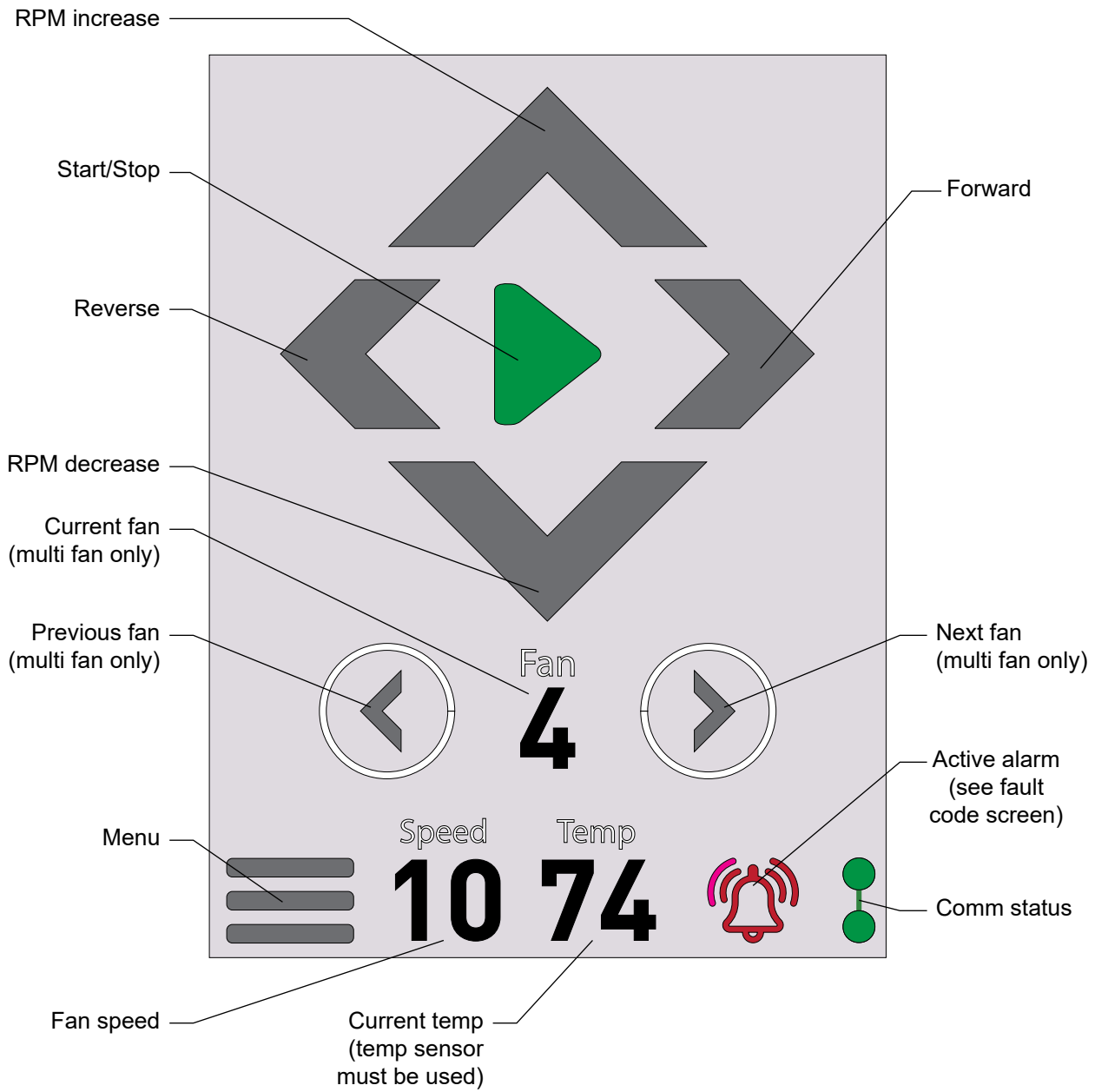

⚠ WARNING

Before operating the industrial fan, read and follow the [Safety Practices on page 8](#), all Warnings, and the [Operating Instructions on page 48](#) in this manual.

Use by untrained personnel could result in death or serious injury.

VERIFY PRIOR TO OPERATION

- The voltage and phase are correct.
- The clearance from obstructions matches the requirements.
- All safety cables are present and properly installed.
- All fasteners are properly torqued.
- No personnel are in the movement area.

LOGIN SCREEN

If the passcode has been enabled, you must login before operating the fan.

The default passcode is 1111.

NORMAL FAN OPERATION

1. Verify the communication status symbol in the bottom right-hand corner is green.
If it is not, communication is not working properly.
2. Press the Start button, and then select the beginning fan rotation direction. See [Figure 44](#).
3. Set the desired speed by pressing either **RPM increase** or **RPM decrease** until your desired speed displays.

Maximum speed is 10.

Minimum speed is 1.

Figure 44



CHANGE THE FAN ROTATION DIRECTION

It is not necessary to stop the fan before changing its rotation.

Select **Forward** or **Reverse**.

DIAGNOSTIC SCREEN

The diagnostic screen shows the following information: See **Figure 45**.

SERVICE PROVIDER INFORMATION

Contact the provider shown on the Corporate Address page for all fan service issues.

FAN INFORMATION

- VFD serial number (If only seven digits are shown, the second group of numbers begins with 0 and is implied.)
- Motor speed (x10)
- Motor current (x10)
- Fan alarm, if an alarm is present
- Fire alarm, if present
- Wind alarm, if enabled and present

BUTTON INFORMATION

The Wind button displays the Wind Control screen.

The Fault Code button displays the Active Alarm screen.

The Temp button displays the Current Temperature screen.

The Passcode button displays the Passcode screen.

The Setup button displays the Setup screen.

Figure 45



FAULT CODES

If a Fault Code alarm displays, press the Fault Code button to display the Active Fault Code screen. See **Figure 46**.

If the fan is currently under a Fault Code, the Active Fault Code number that caused the fault displays in the top right-hand corner of the screen.

To resolve the Fault Code:

1. Press the **Fault Code Directory** button to display a description of the Fault Code.
2. Match the number with the error code in the directory.
3. Resolve the issue causing the fault.
4. Press the **Reset** button to allow the fan to operate.

The last four faults display in the Fault History.

FAULT CODE DEFINITIONS

CODE	DEFINITION	CODE	DEFINITION
0	No alarm/ fan OK	145	PTC thermistor operation
16	Overcurrent during accel	176	Parameter storage device default
17	Overcurrent at speed	177	PU disconnection
18	Overcurrent during decel/stop	178	Retry count excess
32	Overvoltage during accel	192	CPU fault
33	Overvoltage at speed	196	Output current detection value exceeded
34	Overvoltage during decel/stop	197	Inrush current limit circuit fault
48	Inverter overload	199	Analog input fault
49	Motor overload	201	Safety circuit fault
64	Heatsink overheat	245	CPU fault
82	Input phase loss	246	CPU fault
96	Stall prevention	247	CPU fault
112	Brake transistor alarm	250	Inverter output fault
128	Ground fault overcurrent at start	251	Opposite rotation deceleration fault
129	Output phase loss	253	Internal circuit fault
144	External thermal relay operation		

Figure 46



PASSCODE PROTECTION

You can add passcode protection to the remote to prevent unauthorized use. See **Figure 47**.

1. Press the **Menu** button on the main screen.
2. Press the **Passcode** button on the diagnostic screen.
3. Type your passcode.

NOTICE

The default passcode is 1111. If you have customized your passcode, enter your customized passcode.

ENABLE YOUR PASSCODE

By default the passcode is disabled.

Press the unlocked padlock icon to enable the passcode entry requirement.

DISABLE YOUR PASSCODE

Press the locked padlock icon to disable the passcode entry requirement.

UPDATE YOUR PASSCODE

1. Enter your new passcode using the numeric keypad.
2. Press the **Update Passcode** button. See **Figure 48**.

When the passcode is enabled, the system automatically logs you out after two minutes.

MULTI-FAN CONTROL — OPTIONAL

Press the previous or next buttons to select the fan you would like to control. See **Figure 49**.

The All option lets you control all of the fans at the same time.

Figure 47



Figure 48



TEMPERATURE CONTROL — OPTIONAL

To enable the temperature control:

1. Cycle through the start/stop/temp control until you reach Temp. See **Figure 50**.
2. To access the temperature settings screen from the main menu, press the menu button, and then press the Temp button.
3. Type the temperature to start the fan automatically. See **Figure 51**.

At this temperature, the fan automatically starts at speed 2.

4. Type a value to increment the temperature for the next speed setting.

This value is added to the start temperature you entered in the previous step and sets the temperatures at which the fan switches to speeds 4, 6, 8, and 10.

EXAMPLE:

If you enter 70° for the start temperature and enter 3 for the increment value, the fan starts at speed 2 when the temperature is 70°.

When the temperature reaches 73°, the fan switches to speed 4.

When the temperature reaches 76°, the fan switches to speed 6.

The fan decreases in speed as the temperature decreases until the temperature falls below the start point. When the temperature falls below the start point minus the increment value, the fan automatically shuts off.

DISABLE THE TEMPERATURE CONTROL

To disable the temperature control, cycle to Stop or Run from the main screen.

Figure 49



Figure 50



Figure 51

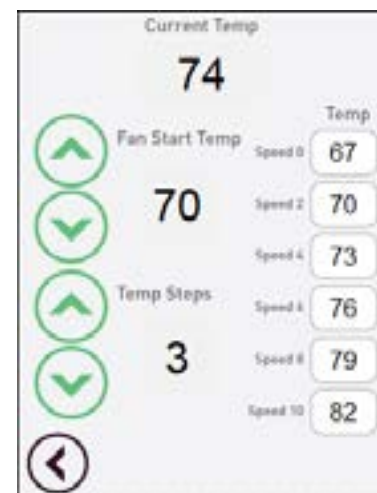

PLANNED MAINTENANCE

▲ DANGER

Before service, inspection or cleaning make sure the power is disconnected and properly locked out.

▲ WARNING

Before servicing the fan, read [Safety Practices on page 8](#) and [Operating Instructions on page 48](#). Failure to do so could result in death or serious injury.

To ensure the continued proper operation of your fan, perform the following planned maintenance annually.

1. Inspect the control panel for loose connections and tighten as required.
2. Using dry air (shop air) blow out debris from the fan motor cooling fan.

NOTICE

The fan motor cooling fan is located on the top of the powerhead motor.

3. Inspect the motor/gearbox for leaks.
 - a. If leaks are present, contact your distributor.
4. If there are any sudden changes in the motor noise or sound, contact your distributor.
5. Inspect the mounting hardware and tighten as required.
 - a. Torque to 44-48 lb-ft.
6. Inspect the safety and guy wires for chaffing or wear.
 - a. Ensure the turnbuckle nut is secure.
 - b. Replace the nut as required.
7. Inspect the guy wires for tension.
 - a. Re-tighten as required.
8. Clean fan blades as required.
 - a. Use a soft dry cloth.
 - b. If necessary, use a mild detergent to clean surfaces.

Figure 52

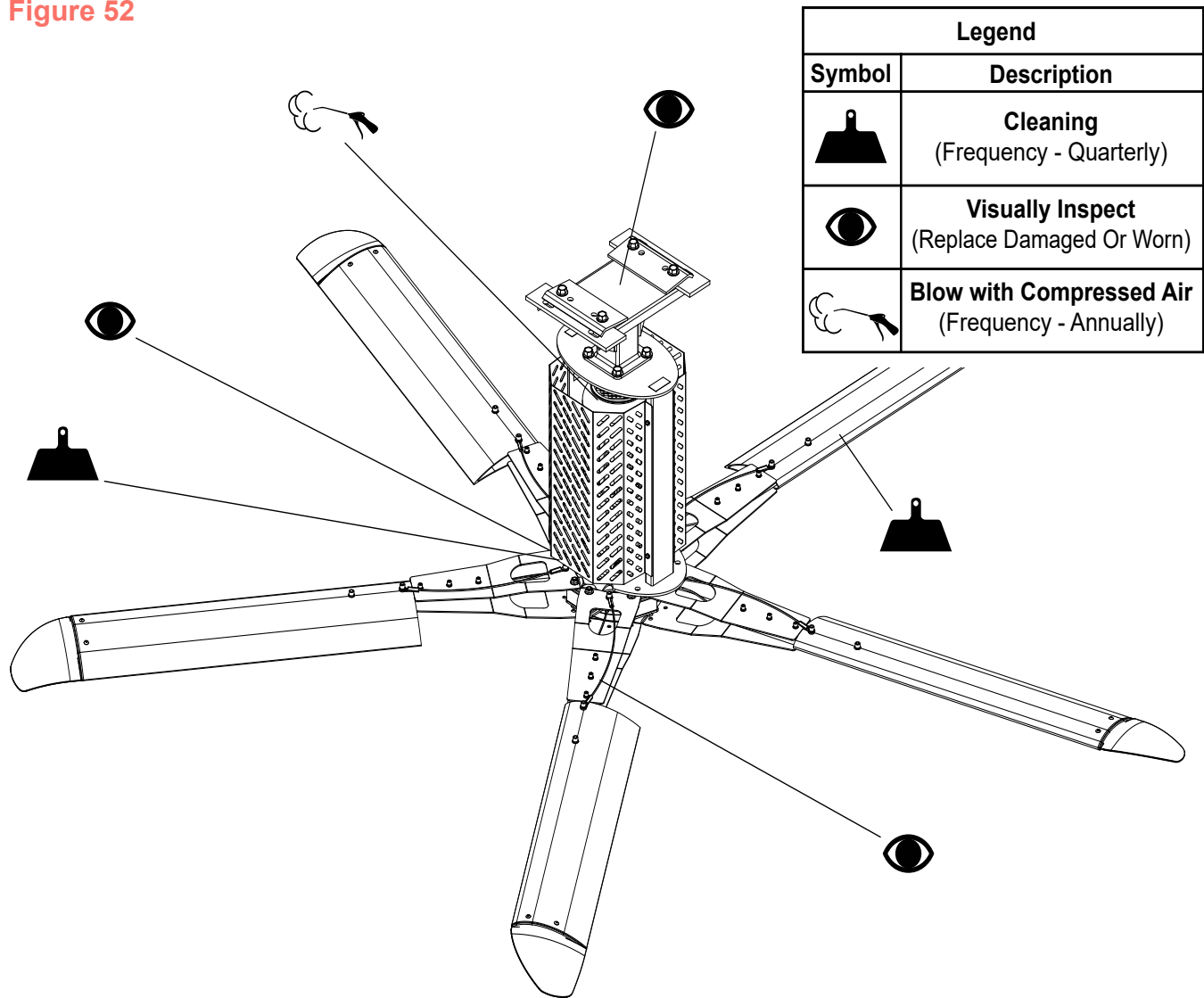

TROUBLESHOOTING GUIDE

▲WARNING

Before servicing the fan, read [Safety Practices on page 8](#) and [Operating Instructions on page 48](#). Failure to do so could result in death or serious injury.

▲DANGER

Before doing any electrical work, make certain the power is disconnected and properly locked out and tagged out.

Failure to do so may result in death or serious injury.

All electrical troubleshooting and repair must be done by a qualified technician and meet all applicable codes.

Do not route control wiring for any other device through this control box.

Ensure the voltage and phase of the incoming power agrees with the label on the top of the VFD box and fan.

Be certain the power is off when wiring to the control box.

Failure to do so may result in electrical shock, death, or serious injury.

The functions of the fan are controlled by a Variable Frequency Drive (VFD). Error codes display on the touchscreen Fault Code screen.

Use the following table to find the condition that most closely matches your situation and make the recommended adjustments.

PROBLEM	POSSIBLE CAUSE	SOLUTION
Fan does not operate.	No power to the control panel.	Ensure the disconnect is in the ON position. Check for primary power at the terminals.
	Primary fuses blown.	Replace fuse(s).
Fan does not operate, but the Control Panel has power.	Obstructions are preventing movement.	Check the fan unit. Ensure there are no obstructions preventing movement.
	Remote not properly connected.	Check the connections between the remote and the VFD.
	VFD faulted.	Check for the VFD fault. Check the fault code action - reset drive. (Power Off/Power On)
	Fire circuit open.	RED fire alarm indicator - The fire alarm is active if the fire alarm circuit is open. Review the building fire system and reset if necessary.
Fan is operating, but turning in the wrong direction.	Wire sequence.	Switch two phases of the output wiring from the VFD to the motor.
	Intermittent connectivity inside the remote control panel.	Make sure the connections inside the remote control touchscreen are secure.
Fan is operating, but shows excessive wobble.	Guy wires are not tensioned properly.	Re-tension the guy wires in accordance with Install the Guy Wires on page 26 .
	Winglet is missing.	Replace the winglet.
The fan is generating a ticking noise and the tick increases with speed.	The blade bolts are not properly tightened.	Loosen the blade nuts. Support the blade level (horizontally) before torquing the bolts to 24-28 lb-ft.

VARIABLE FREQUENCY DRIVE (VFD) FAULT CODES

These codes display on the VFD.

Figure 53

Operation Panel Indication		Name
Error message	<i>E---</i>	E--- Faults history
	<i>HOLD</i>	HOLD Operation panel lock
	<i>LOCd</i>	LOCD Password locked
	<i>Er 1 to Er 4</i>	Er1 to 4 Parameter write error
	<i>Err.</i>	Err. Inverter reset
Warning	<i>OL</i>	OL Stall prevention (overcurrent)
	<i>oL</i>	oL Stall prevention (overvoltage)
	<i>rb</i>	RB Regenerative brake pre-alarm
	<i>TH</i>	TH Electronic thermal relay function pre-alarm
	<i>PS</i>	PS PU stop
	<i>MT</i>	MT Maintenance signal output
	<i>UV</i>	UV Undervoltage
	<i>SA</i>	SA Safety stop
	Alarm	<i>F_n</i>
Fault	<i>E.OC 1</i>	E.OC1 Overcurrent trip during acceleration
	<i>E.OC 2</i>	E.OC2 Overcurrent trip during constant speed
	<i>E.OC 3</i>	E.OC3 Overcurrent trip during deceleration or stop
	<i>E.OV 1</i>	E.OV1 Regenerative overvoltage trip during acceleration
	<i>E.OV 2</i>	E.OV2 Regenerative overvoltage trip during constant speed
	<i>E.OV 3</i>	E.OV3 Regenerative overvoltage trip during deceleration or stop

Operation Panel Indication		Name
Fault	<i>E.THT</i>	E.THT Inverter overload trip (electronic thermal O/L relay function)
	<i>E.THM</i>	E.THM Motor overload trip (electronic thermal O/L relay function)
	<i>E.FIN</i>	E.FIN Heatsink overheat
	<i>E.ILF *</i>	E.ILF * Input phase loss
	<i>E.OLT</i>	E.OLT Stall prevention stop
	<i>E. BE</i>	E. BE Brake transistor alarm detection
	<i>E. GF</i>	E.GF Output side earth (ground) fault overcurrent at start
	<i>E. LF</i>	E.LF Output phase loss
	<i>E.OHT</i>	E.OHT External thermal relay operation
	<i>E.PTC*</i>	E.PTC* PTC thermistor operation
	<i>E. PE</i>	E.PE Parameter storage device fault
	<i>E.PUE</i>	E.PUE PU disconnection
	<i>E.RET</i>	E.RET Retry count excess
	<i>E. S</i>	E.5 CPU fault
	<i>E.CPU</i>	E.CPU CPU fault
	<i>E.CDO*</i>	E.CDO* Output current detection value exceeded
<i>E.IOH *</i>	E.IOH * Inrush current limit circuit fault	
<i>E.AIE *</i>	E.AIE * Analog input fault	
<i>E.SAF *</i>	E.SAF * Safety circuit fault	

COMPONENTS AND SPECIFICATIONS

VFD BOX

- NEMA 1
 - Solid State VFD (Variable Frequency Drive)
 - 3-Blade — 120V-240VAC 1 PH, 208-480V VAC 3PH
 - 5-Blade — 208-240VAC 1PH, 208 – 480 VAC 3PH
 - Line reactor (where required)
 - Class CC fuses
 - UL and UL-C listed panel and components
 - Power disconnect
-

MOTOR

- NEMA standard T.E.F.C
 - 3-Blade – 1 HP
 - 5-Blade – 1-1/2 or 2 HP
 - Continuous duty three phase
-

GEARBOX

- Double helical gear reduced, sealed lubrication.

Figure 54

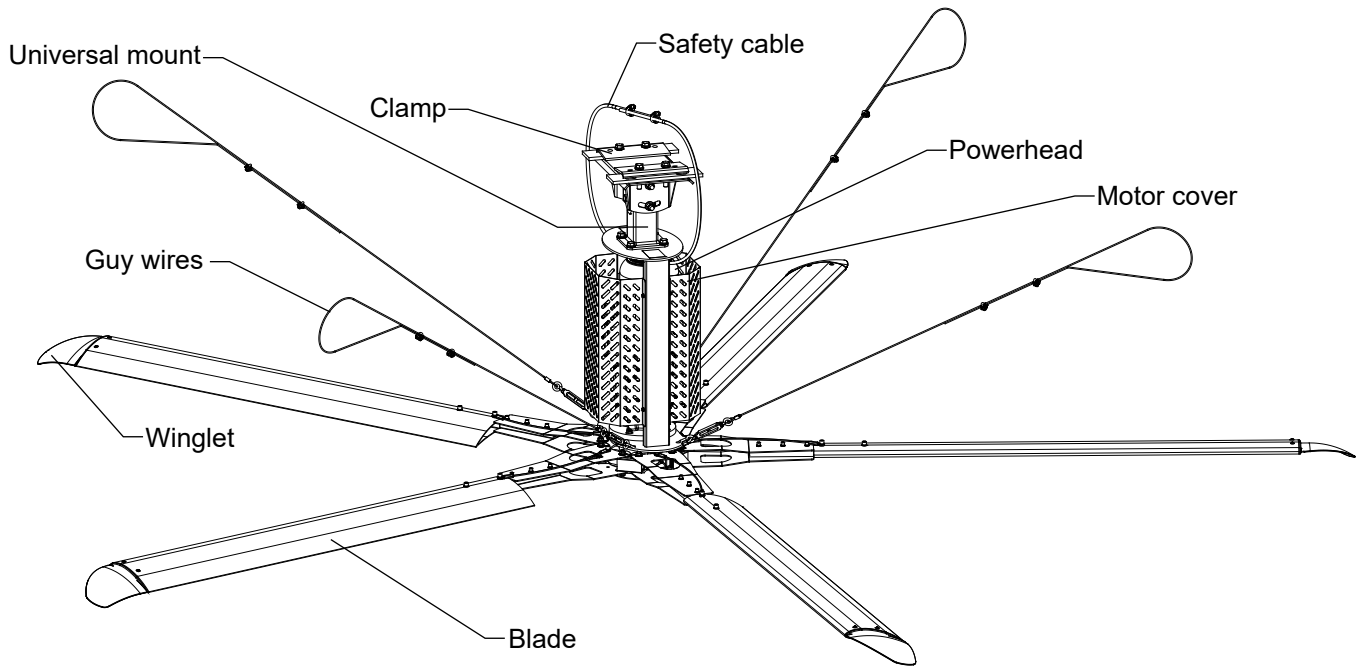
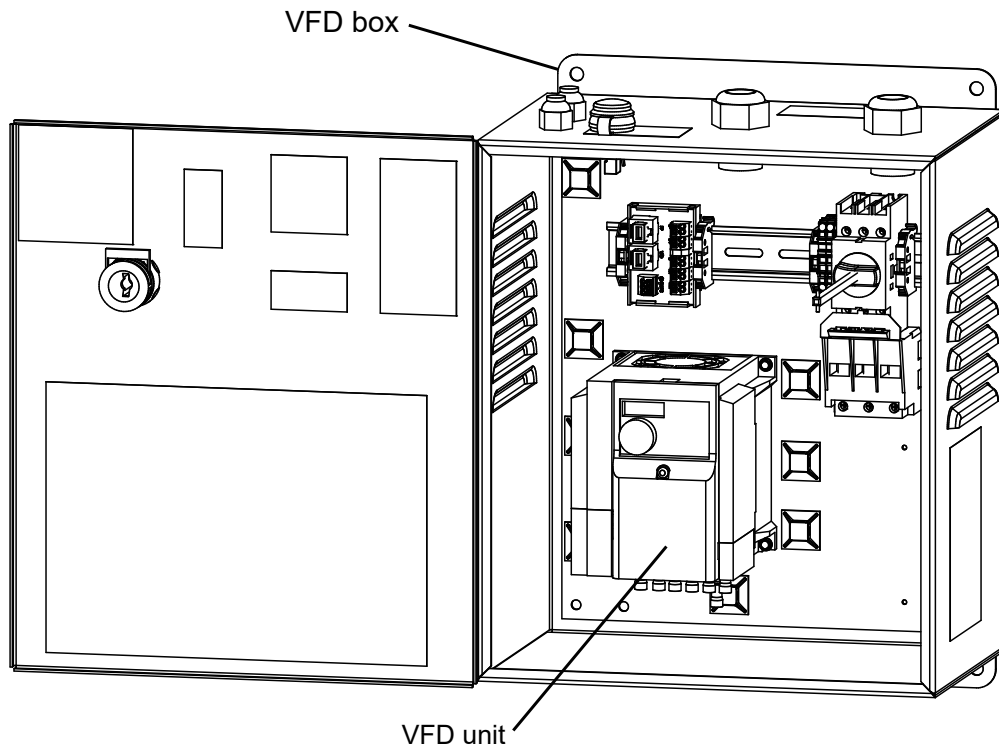

PARTS LIST — FAN

▲ WARNING

To ensure proper function, durability, and safety of the product, only replacement parts that do not interfere with the safe, normal operation of the product must be used.

Incorporation of replacement parts or modifications that weaken the structural integrity of the product, or in any way alter the product from its normal working condition at the time of purchase could result on product malfunction, breakdown, premature wear, death, or serious injury.

Figure 55

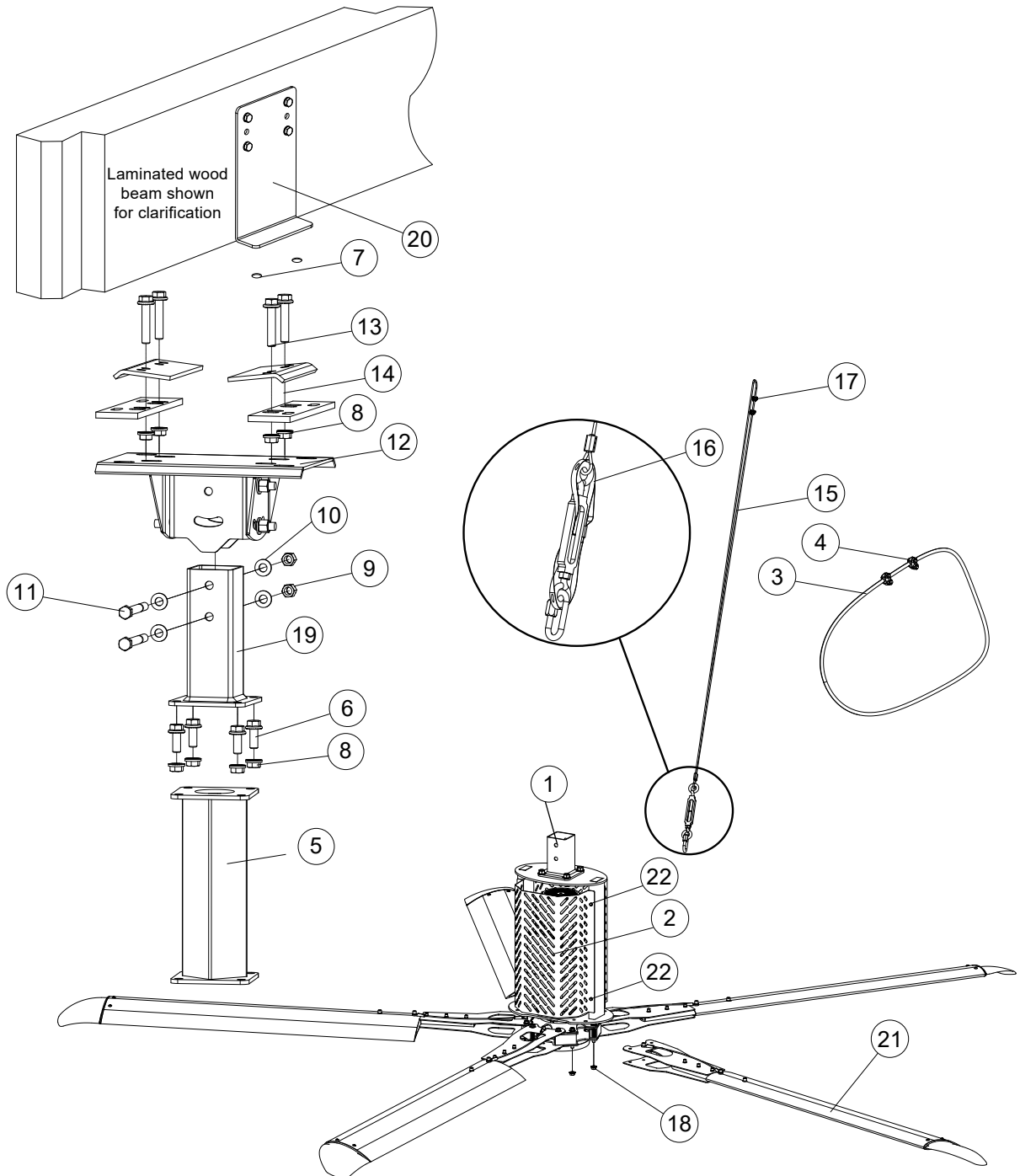

ITEM	QUANTITY	DESCRIPTION	PART NUMBER
1	1	3-BLADE POWERHEAD, 1HP, 8/10 LOW	6025346
		3-BLADE POWERHEAD, 1HP, 8/10 HIGH	6025347
		3-BLADE POWERHEAD, 1HP, 12/14 LOW	6025348
		3-BLADE POWERHEAD, 1HP, 12/14 HIGH	6025349
		3-BLADE POWERHEAD, 1HP, 16/18 LOW	6025350
		3-BLADE POWERHEAD, 1HP, 16/18 HIGH	6025351
		3-BLADE POWERHEAD, 1HP, 20/24 LOW	6025352
		3-BLADE POWERHEAD, 1 HP, 20/24 HIGH	6025353
		5-BLADE POWERHEAD, 1.5HP, 8/10 LOW	6024500
		5-BLADE POWERHEAD, 1.5HP, 8/10 HIGH	6024501
		5-BLADE POWERHEAD, 1.5HP, 12/14 LOW	6024502
		5-BLADE POWERHEAD, 1.5HP, 12/14 HIGH	6024503
		5-BLADE POWERHEAD, 1.5HP, 16/18 LOW	6024504
		5-BLADE POWERHEAD, 1.5HP, 16/18 HIGH	6024505
		5-BLADE POWERHEAD, 1.5HP, 20 LOW	6024506
		5-BLADE POWERHEAD, 1.5HP, 20 HIGH	6024507
		5-BLADE POWERHEAD, 2HP, 24 LOW	6024508
		5-BLADE POWERHEAD, 2HP, 24 HIGH	6024509
2	2	SILVER MOTOR COVER	6015806
		BLACK MOTOR COVER	6015820
3	1	SAFETY CABLE — 170" LONG - 6", 1', 2' EXT	6014884
		SAFETY CABLE — 242" LONG - 3', 4', 5' EXT	6014887
		SAFETY CABLE — 314" LONG - 6', 7', 8' EXT	6014890
		SAFETY CABLE — 386" LONG - 9', 10', 11', 12' EXT	6015864
4	2	CABLE CLAMP 1/4" PLD	441103
5	1	HVLS EXT MNT 12" — optional	6015865
		HVLS EXT MNT 24" — optional	6015866
		HVLS EXT MNT 36" — optional	6015867
		HVLS EXT MNT 48" — optional	6015868
		HVLS EXT MNT 60" — optional	6015869
		HVLS EXT MNT 72" — optional	6015870
		HVLS EXT MNT 84" — optional	6015871
		HVLS EXT MNT 96" — optional	6015872
		HVLS EXT MNT 108" — optional	6015873
		HVLS EXT MNT 120" — optional	6015874
		HVLS EXT MNT 132" — optional	6015875
		HVLS EXT MNT 144" — optional	6015876

ITEM	QUANTITY	DESCRIPTION	PART NUMBER
6	4	SCREW, 1/2-13UNC X 1 1/4" LG SER FLG	6015851
7	4	SCREW, 1/2-13UNC X 2 1/2" LG SER FLG	6015852
8	8	NUT, HEX FLG, SER, 1/2"-13UNC	6015853
9	2	LN 1/2 NYLON INSERT LOCKNUT	214505
10	4	WASHER - 1/2" ID - SAE	234260
11	2	BOLT 1/2"-13UNC X 4 1/2" LG, GRD5	6013220
12	1	PIVOT, EXTRA WIDE HANGER BRACKET MOUNT	6014914
		PIVOT, HANGER BRACKET MOUNT	6016400
13	2	PLATE, HANGER BRACKET CLAMP	6014953
14	2	PLATE, CLAMP SPACER	6014954
15	1	GUY WIRE KIT - 6', 7', 8' EXT (includes items 16 and 17)	6015676
		GUY WIRE KIT - 9', 10' EXT (includes items 16 and 17)	6015678
16	4	SECONDARY STRAP TIE, BALL LOCK	6015265
17	8	1/8" WIRE CABLE CLAMP	6010900
18	20	NUT, HEX FLG, SER, 3/8"-16UNF	6015118
19	1	FAN MOUNT EXTENSION — STD	6020544
20	1	Laminated Wood Beam Bracket Set — optional	6018028

ITEM	QUANTITY	DESCRIPTION	PART NUMBER		
	3-Blade Fans				
21	3	8' BLACK BLADE ASSY	6025355		
		10' BLACK BLADE ASSY	6025357		
		12' BLACK BLADE ASSY	6025358		
		14' BLACK BLADE ASSY	6025360		
		16' BLACK BLADE ASSY	6025361		
		18' BLACK BLADE ASSY	6025388		
		20' BLACK BLADE ASSY	6025390		
		24' BLACK BLADE ASSY	6025392		
		8' CLEAR BLADE ASSY	6025354		
		10' CLEAR BLADE ASSY	6025356		
		12' CLEAR BLADE ASSY	6021936		
		14' CLEAR BLADE ASSY	6025359		
		16' CLEAR BLADE ASSY	6021933		
		18' CLEAR BLADE ASSY	6025387		
		20' CLEAR BLADE ASSY	6021932		
		24' CLEAR BLADE ASSY	6025391		
			5-Blade Fans		
			5	8' BLACK BLADE ASSY	6020503
		10' BLACK BLADE ASSY		6020504	
		12' BLACK BLADE ASSY		6020505	
		14' BLACK BLADE ASSY		6020506	
		16' BLACK BLADE ASSY		6020507	
		18' BLACK BLADE ASSY		6020508	
		20' BLACK BLADE ASSY		6020509	
		24' BLACK BLADE ASSY		6020511	
		8' CLEAR BLADE ASSY		6020512	
	10' CLEAR BLADE ASSY	6020513			
	12' CLEAR BLADE ASSY	6020514			
	14' CLEAR BLADE ASSY	6020515			
	16' CLEAR BLADE ASSY	6020516			
	18' CLEAR BLADE ASSY	6020517			
	20' CLEAR BLADE ASSY	6020518			
	24' CLEAR BLADE ASSY	6020520			
22	8	Fan Cover Fasteners	215702		

PARTS LIST — VFD BOX

Figure 56

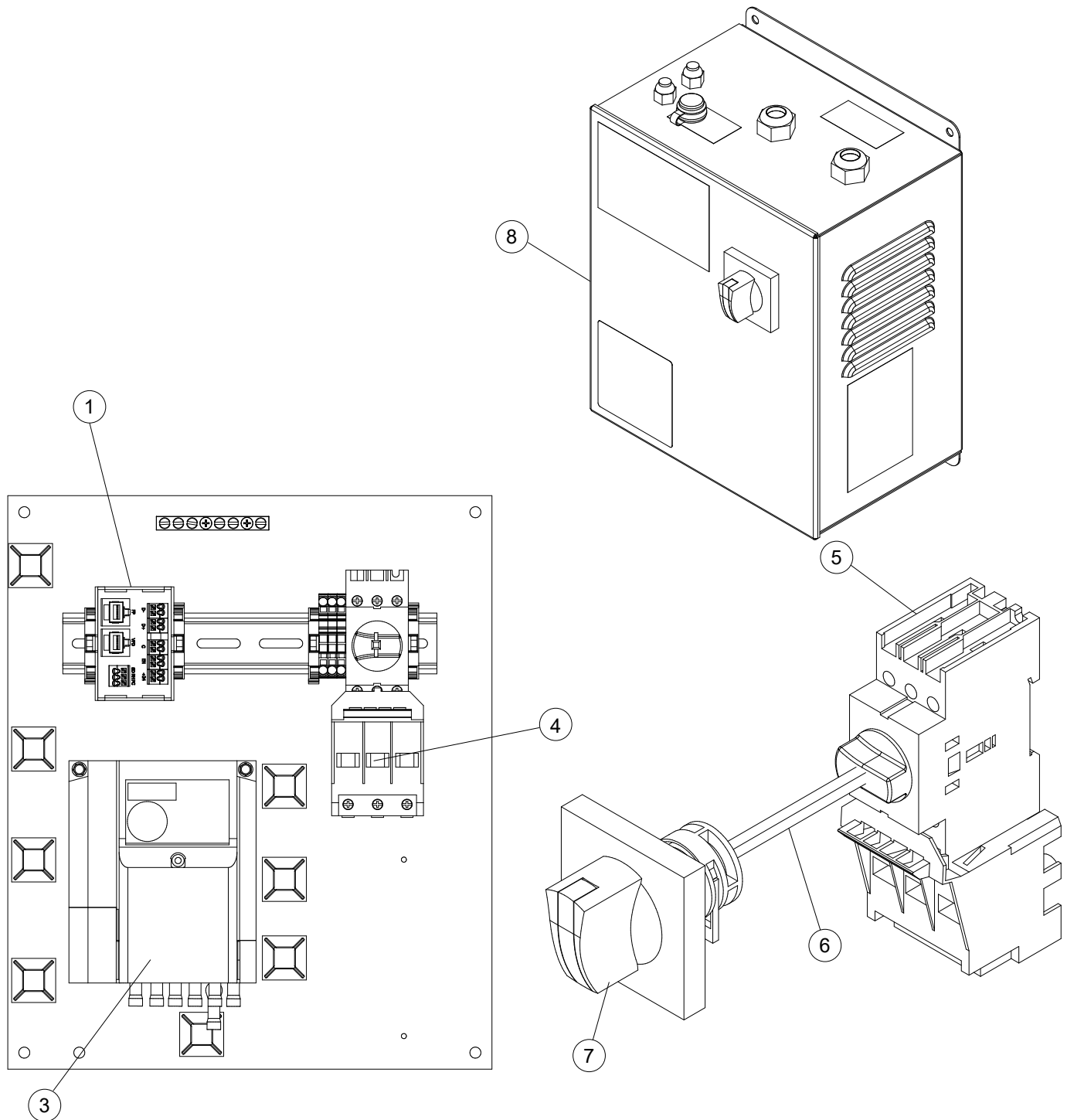

3-BLADE**6025193 — 120V/1PH/1HP**

ITEM	QUANTITY	PART DESCRIPTION	PART NUMBER
1	1	INTERFACE, HVLS DIN RAIL MOUNT PCB	6015547
2	—	—	—
3	1	mitsubishi VFD, 120V, 1PH, 1HP	6014902
4	2	FUSE 20A, 600V, KTK-R-20	6011801
5	1	ROTARY DISCONNECT	6021193
6	1	DISCONNECT SHAFT 150MM	6021194
7	1	DISCONNECT HANDLE	6021191
8	1	VFD CONTROL BOX ASSY (includes items 1-7)	6025193

6025278 — 230V/1PH/1HP

ITEM	QUANTITY	PART DESCRIPTION	PART NUMBER
1	1	INTERFACE, HVLS DIN RAIL MOUNT PCB	6015547
2	—	—	—
3	1	mitsubishi VFD, 230V, 3PH, 2HP	6014907
4	2	FUSE 15A, 600V, KTK-R-15	6011800
5	1	ROTARY DISCONNECT	6021193
6	1	DISCONNECT SHAFT 150MM	6021194
7	1	DISCONNECT HANDLE	6021191
8	1	VFD CONTROL BOX ASSY (includes items 1-7)	6025278

6025279 — 230V/3PH/1HP

ITEM	QUANTITY	PART DESCRIPTION	PART NUMBER
1	1	INTERFACE, HVLS DIN RAIL MOUNT PCB	6015547
2	—	—	—
3	1	mitsubishi VFD, 230V, 1PH, 2HP	6014907
4	2	FUSE 15A, 600V, KTK-R-15	6011800
5	1	ROTARY DISCONNECT	6021193
6	1	DISCONNECT SHAFT 150MM	6021194
7	1	DISCONNECT HANDLE	6021191
8	1	VFD CONTROL BOX ASSY (includes items 1-7)	6025279

6025280 — 460V/3PH/1HP

ITEM	QUANTITY	PART DESCRIPTION	PART NUMBER
1	1	INTERFACE, HVLS DIN RAIL MOUNT PCB	6015547
2	—	—	—
3	1	mitsubishi VFD, 230V, 1PH, 2HP	6014909
4	2	FUSE 10A, 600V, KTK-R-10	6014015
5	1	ROTARY DISCONNECT	6021193
6	1	DISCONNECT SHAFT 150MM	6021194
7	1	DISCONNECT HANDLE	6021191
8	1	VFD CONTROL BOX ASSY (includes items 1-7)	6025280

5-BLADE**6024603 — 230V/1PH/1.5HP**

ITEM	QUANTITY	PART DESCRIPTION	PART NUMBER
1	1	INTERFACE, HVLS DIN RAIL MOUNT PCB	6015547
2	—	—	—
3	1	mitsubishi VFD, 230V, 1PH, 2HP	6014904
4	2	FUSE 20A, 600V, KTK-R-20	6011801
5	1	ROTARY DISCONNECT	6021193
6	1	DISCONNECT SHAFT 150MM	6021194
7	1	DISCONNECT HANDLE	6021191
8	1	VFD CONTROL BOX ASSY (includes items 1-7)	6024603

6024606 — 230V/1PH/2HP

ITEM	QUANTITY	PART DESCRIPTION	PART NUMBER
1	1	INTERFACE, HVLS DIN RAIL MOUNT PCB	6015547
2	—	—	—
3	1	mitsubishi VFD, 230V, 1PH, 2HP	6014904
4	2	FUSE 20A, 600V, KTK-R-20	6011801
5	1	ROTARY DISCONNECT	6021193
6	1	DISCONNECT SHAFT 150MM	6021194
7	1	DISCONNECT HANDLE	6021191
8	1	VFD CONTROL BOX ASSY (includes items 1-7)	6024606

6024604 — 230V3PH/1.5HP

ITEM	QUANTITY	PART DESCRIPTION	PART NUMBER
1	1	INTERFACE, HVLS DIN RAIL MOUNT PCB	6015547
2	—	—	—
3	1	mitsubishi VFD, 230V, 3PH, 2HP	6014907
4	3	FUSE 15A, 600V, KTK-R-15	6011800
5	1	ROTARY DISCONNECT	6021193
6	1	DISCONNECT SHAFT 150MM	6021194
7	1	DISCONNECT HANDLE	6021191
8	1	VFD CONTROL BOX ASSY (includes items 1-7)	6024604

6024607 — 230V/3PH/2HP

ITEM	QUANTITY	PART DESCRIPTION	PART NUMBER
1	1	INTERFACE, HVLS DIN RAIL MOUNT PCB	6015547
2	—	—	—
3	1	MITSUBISHI VFD, 230V, 3PH, 2HP	6014907
4	3	FUSE 15A, 600V, KTK-R-15	6011800
5	1	ROTARY DISCONNECT	6021193
6	1	DISCONNECT SHAFT 150MM	6021194
7	1	DISCONNECT HANDLE	6021191
8	1	VFD CONTROL BOX ASSY (includes items 1-7)	6024607

6024605 — 460V/3PH/1.5HP

ITEM	QUANTITY	PART DESCRIPTION	PART NUMBER
1	1	INTERFACE, HVLS DIN RAIL MOUNT PCB	6015547
2	—	—	—
3	1	MITSUBISHI VFD, 480V, 3PH, 2HP	6014909
4	3	FUSE 10A, 600V, KTK-R-10	6014015
5	1	ROTARY DISCONNECT	6021193
6	1	DISCONNECT SHAFT 150MM	6021194
7	1	DISCONNECT HANDLE	6021191
8	1	VFD CONTROL BOX ASSY (includes items 1-7)	6024605

6024608 — 460V/3PH/2PH

ITEM	QUANTITY	PART DESCRIPTION	PART NUMBER
1	1	INTERFACE, HVLS DIN RAIL MOUNT PCB	6015547
2	—	—	—
3	1	mitsubishi VFD, 480V, 3PH, 2HP	6014909
4	3	FUSE 10A, 600V, KTK-R-10	6014015
5	1	ROTARY DISCONNECT	6021193
6	1	DISCONNECT SHAFT 150MM	6021194
7	1	DISCONNECT HANDLE	6021191
8	1	VFD CONTROL BOX ASSY (includes items 1-7)	6024608

6024443 — 460V/3PH/1.5HP

ITEM	QUANTITY	PART DESCRIPTION	PART NUMBER
1	1	INTERFACE, HVLS DIN RAIL MOUNT PCB	6015547
2	1	LINE REACTOR, 600V, 3.4A	6010718
3	1	MITSUBISHI VFD, 480V, 3PH, 3HP	6016452
4	3	FUSE 10A, 600V, KTK-R-10	6014015
5	1	ROTARY DISCONNECT	6021193
6	1	DISCONNECT SHAFT 150MM	6021194
7	1	DISCONNECT HANDLE	6021191
8	1	VFD CONTROL BOX ASSY (includes items 1-7)	6024443

6024442 — 480V/3PH/2HP

ITEM	QUANTITY	PART DESCRIPTION	PART NUMBER
	1	INTERFACE, HVLS DIN RAIL MOUNT PCB	6015547
2	1	LINE REACTOR, 600V, 4.8A	6010719
3	1	MITSUBISHI VFD, 480V, 3PH, 3HP	6016452
4	3	FUSE 10A, 600V, KTK-R-10	6014015
5	1	ROTARY DISCONNECT	6021193
6	1	DISCONNECT SHAFT 150MM	6021194
7	1	DISCONNECT HANDLE	6015598
8	1	VFD CONTROL BOX ASSY (includes items 1-7)	6024442

PARTS LIST — REMOTE CONTROL PANEL

Figure 57

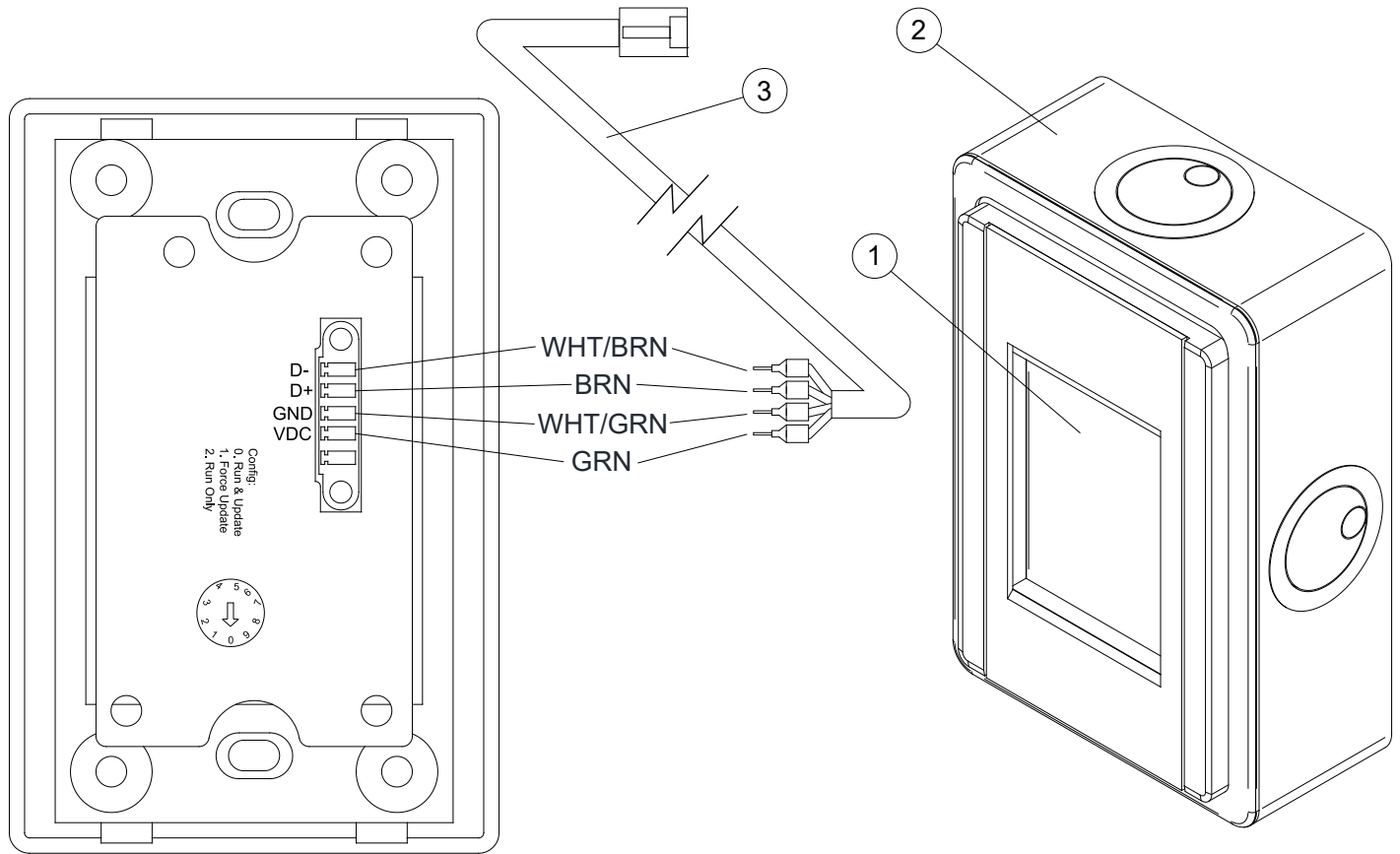

ITEM	QUANTITY	PART DESCRIPTION	PART NUMBER
1	1	TOUCH SCREEN CONTROLLER, KELLEY	6015758
		TOUCH SCREEN CONTROLLER, SERCO	6015759
		TOUCH SCREEN CONTROLLER, EPIC	6023293
2	1	J-BOX , PLASTIC, IVORY	6015648
3	1	CABLE CAT5, 100' W/ FERRULE (blue)	6015651

PARTS LIST — TEMP CONTROL (OPTIONAL) - 6022769

Figure 58

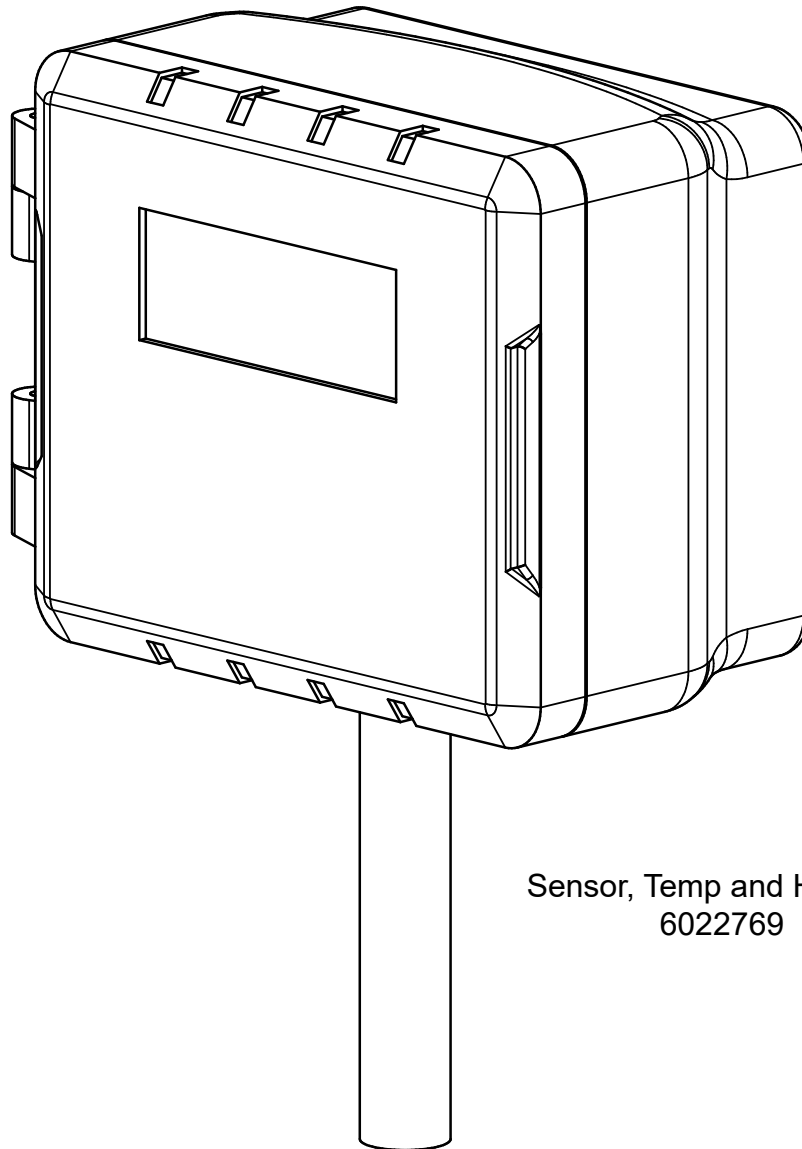

Sensor, Temp and Humidity
6022769

Please direct questions about your fan to your local distributor. Your local distributor is:

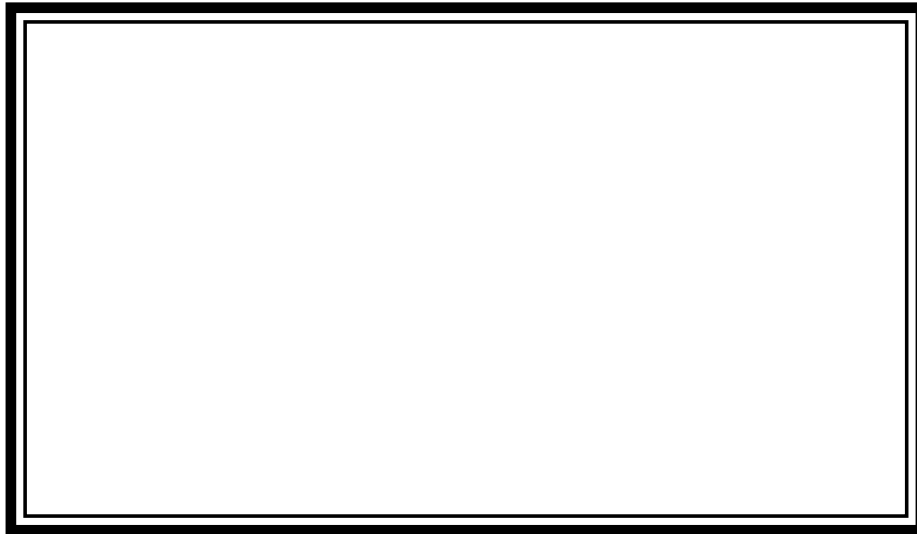

Corporate Office

1612 Hutton Drive, Suite 140

Carrollton, TX 75006

Tel: (972) 466-0707

Fax: (972) 323-2661



APS Resource

262.518.1000

Scan this code or click [here](#) to locate an APS Resource distributor.

For replacement parts, please call the number above.